

FOLLONI

AIR COMPRESSORS



Catalogo
Catalogue



**QUALITY
MADE IN ITALY**

POWERED by
HONDA™



Compressori a pistoni
Piston compressors



COMPANY PROFILE



Produced by LA PADANA Air Compressors

Cinquanta anni d'esperienza nel campo nell'aria compressa al servizio della nostra clientela.

I compressori "LA PADANA" sono stati progettati e realizzati per soddisfare le richieste più esigenti: facilità d'uso e manutenzione, silenziosità, massima efficienza energetica, per fornire in modo affidabile ed economico aria compressa della miglior qualità

Queste richieste sono totalmente soddisfatte grazie al risultato di una progettazione e di una costruzione accurata, capace di integrare e ottimizzare le più avanzate soluzioni tecniche in tutte le aree cruciali come gruppi vite, controller basati su PC industriali, motori ad elevata efficienza, concetti innovativi di ventilazione e raffreddamento, insonorizzazione, manutenzione e service.

La nostra gamma di produzione è disponibile sul mercato nazionale e internazionale con potenze da 2,2kW a 150kW, offerte in un ampio ventaglio di opzioni standard e speciali.

I compressori prodotti da LA PADANA sono distribuiti in tutto il mondo tramite un'efficiente rete di rivenditori

More than 50 years of experience in the industry of air compressors

"La Padana" compressors are designed and manufactured to satisfy the most demanding requirements: ease of use and maintenance, quiet operation, maximum energy efficiency, to reliably and economically supply the best quality compressed air.

These demands are fully met as a result of careful design and construction, capable of integrating and optimizing the most advanced technical solutions in all crucial areas such as screw assemblies, industrial PC-based controllers, high-efficiency motors, innovative ventilation and cooling concepts, soundproofing, maintenance and service.

Our production range is available in the domestic and international market with powers from 2.2kW to 132kW, offered in a wide range of standard and special options.

The compressors manufactured by LA PADANA are distributed all over the world through efficient retailers.



QUALITY and CERTIFICATION



La nostra priorità è la QUALITÀ dei nostri prodotti, sono infatti 100% Made in Italy.

Tutti i compressori FOLLONI Air Compressors sono prodotti in conformità a:



- ✓ 2006/42/CE Direttiva Macchine;
- ✓ 2014/29/CE Direttiva recipienti semplici a pressione;
- ✓ 2014/35/UE Direttiva bassa tensione;
- ✓ 2014/30/UE Compatibilità elettro magnetica;
- ✓ EN ISO 3746 potenza sonora;
- ✓ IEC 60034-2-1 motori elettrici



Certificazioni di qualità dei nostri prodotti:

- ✓ EC Direttive Europee;
- ✓ Certificazione Russa GOST-R;
- ✓ Certificazione Asme per i serbatoi d'aria compressa
- ✓ Certificazione Australiana per i serbatoi d'aria compressa



Our priority is the QUALITY of our products, they are 100% made in Italy.

All FOLLONI air compressors are manufactured in compliance with:



- ✓ 2006/42/CE Machinery Directive;
- ✓ 2014/29/CE simple pressure Vessels Directive;
- ✓ 2014/35/UE Low Voltage Directive;
- ✓ 2014/30/UE Electromagnetic compatibility;
- ✓ EN ISO 3746 Noise level;
- ✓ IEC 60034-2-1 Electric Motors



Our products quality certification:

- ✓ EC European Directives;
- ✓ Russian GOST-R Certification;
- ✓ Asme certification for compressed air tank
- ✓ Australian certification for compressed air tank



Indice Generale

General Index

EASY.....	Pag. 4
GRUPPI K.....	Pag. 14
INDUSTRIAL.....	Pag. 16
INDUSTRIAL SILENT LS.....	Pag. 28
MPC.....	Pag. 36
PAB.....	Pag. 38
PAS.....	Pag. 40
MOTO KOMP.....	Pag. 42
GENAIR.....	Pag. 48
PRO AIR SUPER SILENT.....	Pag. 51
COMPRESSORS PUMPS.....	Pag. 53

TABELLA DI CONVERSIONE

1 cfm = 28,317 l/min
 $^{\circ}\text{F} = ^{\circ}\text{C} \times 9/5 + 32$
 1 psi = 0,068 bar
 1 Pa = 0,00001 bar
 1 lbs = 0,45 kg
 1 US gall = 3,78 lt

CONVERSION TABLE:

1 m³/min = 35,314 cfm
 $\text{C}^{\circ} = (\text{F}^{\circ} - 32) \times 5/9$
 1 bar = 14,50 psi
 1 bar = 100 kPa
 1 kg = 2,2 lbs
 1 lt = 0,26 gall (USA)

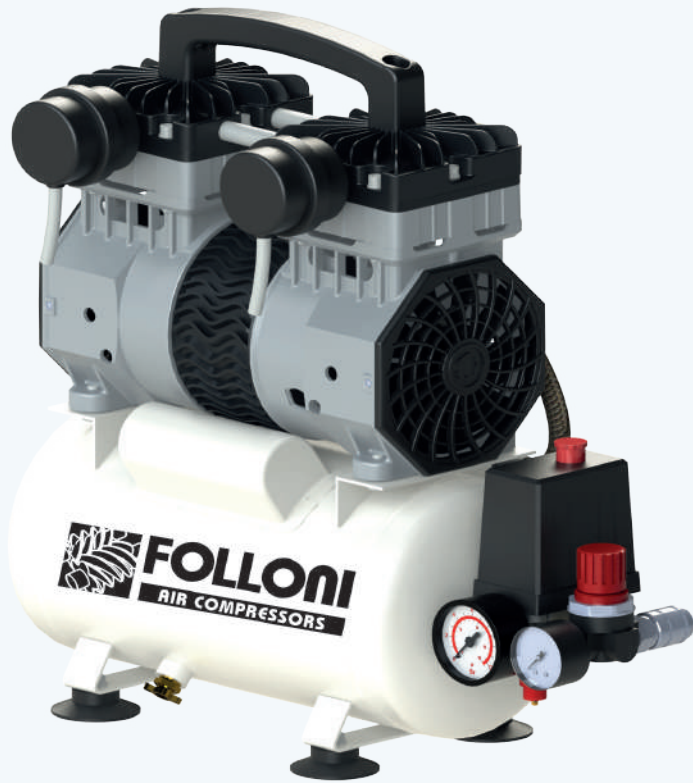

serie/series:

COMPRESSORI OIL - FREE OIL - FREE COMPRESSORS

**QUALITY
MADE IN ITALY**

COMPRESSORI PROFESSIONALI - BISTADIO - TRASMISSIONE DIRETTA - OILFREE
PROFESSIONAL COMPRESSORS - DOUBLE STAGE - DIRECT TRASMISSION - OILFREE



PS 16



PS 1D



PS 24



Max 61 dB(A)

PS SERIES

Codice	Modello	Pressione		N. Cilindri	Potenza Nominale Motore		Aria Aspirata			Serb.	Voltaggio	Giri/min	Peso	Dimensione Imballo
Cod.	Model	Pressure		N. Cylinders	Nominal Motor Rating		Air Displacement			Tank	Voltage	r.p.m.	Weight	Packaging Dimension
-	Series	bar	p.s.i.	Cil.	Hp	kW	lt./min.	CFM	m3/h	lt.	Volt/ph/hz	r.p.m.	kg.	cm
80615	PS 1 D	8	116	2	1	0,75	160	6	10	-	230/1/50	2800	8	-
80601	PS 14	8	116	2	1	0,75	160	6	10	4F	230/1/50	2800	15	32x45x45
80614	PS 16	8	116	2	1	0,75	160	6	10	6F	230/1/50	2800	15	47x32x53
80602	PS 24	8	116	2	2	1,5	260	9	15,6	4F	230/1/50	2800	18	32x45x45

serie/series:

EASY-D

**QUALITY
MADE IN ITALY**

COMPRESSORI SEMIPROFESSIONALI - MONOSTADIO TRASMISSIONE DIRETTA COASSIALE - LUBRIFICATI
OIL - LUBRICATED SINGLE-STAGE SEMI-PROFESSIONAL COMPRESSORS WITH DIRECT COAXIAL DRIVE



Max 76 dB(A)

ED 25/2 M

ED SERIES

Codice	Modello	Pressione		N. Cilindri	Potenza Nominale Motore		Aria Aspirata			Serb.	Voltaggio	Giri/min	Peso	Dimensione Imballo
Cod.	Model	Pressure		N. Cylinders	Nominal Motor Rating		Air Displacement			Tank	Voltage	r.p.m.	Weight	Packaging Dimension
-	Series	bar	p.s.i.	Cil.	Hp	kW	lt./min.	CFM	m3/h	lt.	Volt/ph/hz	r.p.m.	kg.	cm
COMPRESSORI MONOFASI CARRELLATI - PORTABLE SINGLE PHASE COMPRESSORS														
91016	ED 25/2M	8	116	1	2	1,5	240	9	14,4	25 C	230/1/50	2800	27	60x28x59
91017	ED 50/2M	8	116	1	2	1,5	240	9	14,4	50 C	230/1/50	2800	35	85x38x73

serie/series:

EASY-C

**QUALITY
MADE IN ITALY**

COMPRESSORI PROFESSIONALI - MONOSTADIO TRASMISSIONE A CINGHIA - LUBRIFICATI
OIL - LUBRIFICATED SINGLE-STAGE PROFESSIONAL COMPRESSORS WITH BELT DRIVE

Max 76 dB(A)



ECW 50/2M



ECW 100/2M

ECW SERIES - 2 HP

Codice	Modello	Pressione		N. Cilindri	Potenza Nominale Motore		Aria Aspirata			Serb.	Voltaggio	Giri/min	Peso	Dimensione Imballo
Cod.	Model	Pressure		N. Cylinders	Nominal Motor Rating		Air Displacement			Tank	Voltage	r.p.m.	Weight	Packaging Dimension
-	Series	bar	p.s.i.	Cil.	Hp	kW	lt./min.	CFM	m3/h	lt.	Volt/ph/hz	r.p.m.	kg.	cm
COMPRESSORI MONOFASI CARRELLATI - PORTABLE SINGLE PHASE COMPRESSORS														
91031.0.0	ECW 50/2M									50 C	230/1/50		41	85x38x73
91032.0.0	ECW 100/2M	10	145	2	2	1,5	255	9	15,3	100 C	230/1/50		53	100x40x80
91032.1.1	ECW 150/2M									150 C	230/1/50		71	132x45x92

*SC: senza collettore / without aftercooler

serie/series:

EASY-C

**QUALITY
MADE IN ITALY**

COMPRESSORI PROFESSIONALI - MONOSTADIO TRASMISSIONE A CINGHIA - LUBRIFICATI OIL - LUBRIFICATED SINGLE-STAGE PROFESSIONAL COMPRESSORS WITH BELT DRIVE



Max 76 dB(A)

ECW 100/3M



ECW 200/3M

ECW SERIES - 3 HP

Codice	Modello	Pressione		N. Cilindri	Potenza Nominale Motore		Aria Aspirata			Serb.	Voltaggio	Giri/min	Peso	Dimensione Imballo
Cod.	Model	Pressure		N. Cilinders	Nominal Motor Rating		Air Displacement			Tank	Voltage	r.p.m.	Weight	Packaging Dimension
-	Series	bar	p.s.i.	Cil.	Hp	kW	lt./min.	CFM	m3/h	lt.	Volt/ph/hz	r.p.m.	kg.	cm
COMPRESSORI MONOFASI CARRELLATI - PORTABLE SINGLE PHASE COMPRESSORS														
91046.0.0	ECW 50/3M	10	145	2	3	2,2	330	11,6	19,8	50 C	230/1/50	1620	44	85x38x73
91042.0.0	ECW 100/3M									100 C	230/1/50		56	100x40x80
91043.0.0	ECW 150/3M									150 C	230/1/50		74	132x45x92
91044.0.0	ECW 200/3M									200 C	230/1/50		89	145x46x94
COMPRESSORI TRIFASE CARRELLATI - PORTABLE THREE PHASES COMPRESSORS														
91036.0.0	ECW 100/3T	10	145	2	3	2,2	330	11,6	19,8	100 C	400/3/50	1620	56	100x40x80
91040.0.0	ECW 150/3T									150 C	400/3/50		74	132x45x92
91037.0.0	ECW 200/3T									200 C	400/3/50		89	145x46x94

serie/series:

EASY-C

**QUALITY
MADE IN ITALY**

COMPRESSORI PROFESSIONALI - MONOSTADIO TRASMISSIONE A CINGHIA - LUBRIFICATI OIL - LUBRIFICATED SINGLE-STAGE PROFESSIONAL COMPRESSORS WITH BELT DRIVE

Max 76 dB(A)



EC 25/2 M



EC 50/2 M



EC 100/2 M

EC SERIES - 2 HP

Codice	Modello	Pressione		N. Cilindri	Potenza Nominale Motore		Aria Aspirata			Serb.	Voltaggio	Giri/min	Peso	Dimensione Imballo
Cod.	Model	Pressure		N. Cilinders	Nominal Motor Rating		Air Displacement			Tank	Voltage	r.p.m.	Weight	Packaging Dimension
-	Series	bar	p.s.i.	Cil.	Hp	kW	lt./min.	CFM	m3/h	lt.	Volt/ph/hz	r.p.m.	kg.	cm
COMPRESSORI MONOFASI CARRELLATI - PORTABLE SINGLE PHASE COMPRESSORS														
91030	EC 25/2M	10	145	2	2	1,5	253	8,9	15,2	25 C	230/1/50	1400	40	77x35x69
91031	EC 50/2M									50 C	230/1/50		48	85x38x73
91032	EC 100/2M									100 C	230/1/50		62	100x40x80
91032.1.0	EC 150/2M									150 C	230/1/50		71	132x45x92
COMPRESSORI TRIFASE CARRELLATI - PORTABLE THREE PHASES COMPRESSORS														
91034	EC 50/2T	10	145	2	2	1,5	253	8,9	15,2	50 C	400/3/50	1400	48	85x38x73
91035	EC 100/2T									100 C	400/3/50		62	100x40x80
91032.1.0.1	EC 150/2T									150 C	400/3/50		71	132x45x92

serie/series:

EASY-C

**QUALITY
MADE IN ITALY**

COMPRESSORI PROFESSIONALI - MONOSTADIO TRASMISSIONE A CINGHIA - LUBRIFICATI
OIL - LUBRIFICATED SINGLE-STAGE PROFESSIONAL COMPRESSORS WITH BELT DRIVE

Max 75 dB(A)



EC 200/3 T

EC SERIES - 3 HP

Codice	Modello	Pressione		N. Cilindri	Potenza Nominale Motore		Aria Aspirata			Serb.	Voltaggio	Giri/min	Peso	Dimensione Imballo
Cod.	Model	Pressure		N. Cylinders	Nominal Motor Rating		Air Displacement			Tank	Voltage	r.p.m.	Weight	Packaging Dimension
-	Series	bar	p.s.i.	Cil.	Hp	kW	lt./min.	CFM	m3/h	lt.	Volt/ph/hz	r.p.m.	kg.	cm
COMPRESSORI MONOFASI CARRELLATI - PORTABLE SINGLE PHASE COMPRESSORS														
91046	EC 50/3M	10	145	2	3	2,2	315	11,1	18,9	50 C	230/1/50	1400	57	85x38x73
91042	EC 100/3M									100 C	230/1/50		67	100x40x80
91043	EC 150/3M									150 C	230/1/50		86	132x45x92
91044	EC 200/3M									200 C	230/1/50		96	145x46x94
91045	EC 270/3M									270 C	230/1/50		112	155x57x112
COMPRESSORI TRIFASE CARRELLATI - PORTABLE THREE PHASES COMPRESSORS														
91047	EC 50/3T	10	145	2	3	2,2	315	11,1	18,9	50 C	400/3/50	1400	57	85x38x73
91036	EC 100/3T									100 C	400/3/50		67	100x40x80
91040	EC 150/3T									150 C	400/3/50		86	132x45x92
91037	EC 200/3T									200 C	400/3/50		96	145x46x94
91041	EC 270/3T									270 C	400/3/50		112	155x57x112

serie/series:

EASY-C

**QUALITY
MADE IN ITALY**

COMPRESSORI PROFESSIONALI - MONOSTADIO TRASMISSIONE A CINGHIA - LUBRIFICATI
OIL - LUBRIFICATED SINGLE-STAGE PROFESSIONAL COMPRESSORS WITH BELT DRIVE

Max 74 dB(A)



EC 270/4 T

EC SERIES - 4 HP

Codice	Modello	Pressione		N. Cilindri	Potenza Nominale Motore		Aria Aspirata			Serb.	Voltaggio	Giri/min	Peso	Dimensione Imballo
Cod.	Model	Pressure		N. Cylinders	Nominal Motor Rating		Air Displacement			Tank	Voltage	r.p.m.	Weight	Packaging Dimension
-	Series	bar	p.s.i.	Cil.	Hp	kW	ft. min.	CFM	m3/h	lt.	Volt/ph/hz	r.p.m.	kg.	cm
COMPRESSORI TRIFASE CARRELLATI - PORTABLE THREE PHASES COMPRESSORS														
91048	EC 100/4T	10	145	2	4	3	541	19,1	32,5	100 C	400/3/50	1400	98	100x40x80
91049	EC 150/4T									150 C	400/3/50		113	132x45x92
91038	EC 200/4T									200 C	400/3/50		123	145x46x94
91039	EC 270/4T									270 C	400/3/50		139	155x57x112
COMPRESSORI TRIFASE FISSI - FIXED THREE PHASES COMPRESSORS														
91051	EC 200/4T	10	145	2	4	3	541	19,1	32,5	200 F	400/3/50	1400	123	145x46x94
91052	EC 270/4T									270 F	400/3/50		139	155x57x112

serie/series:

EASY-C

**QUALITY
MADE IN ITALY**

COMPRESSORI PROFESSIONALI - BISTADIO TRASMISSIONE A CINGHIA - LUBRIFICATI
OIL - LUBRICATED DOUBLE-STAGE PROFESSIONAL COMPRESSORS WITH BELT DRIVE

Max 81 dB(A)



EC 270/5,5 T

EC SERIES - 5,5 HP

Codice	Modello	Pressione		N. Cilindri	Potenza Nominale Motore			Aria Aspirata			Serb.	Voltaggio	Giri/min	Peso	Dimensione Imballo
Cod.	Model	Pressure		N. Cylinders	Nominal Motor Rating			Air Displacement			Tank	Voltage	r.p.m.	Weight	Packaging Dimension
-	Series	bar	p.s.i.	Cil.	Hp	kW	lt./min.	CFM	m3/h	lt.	Volt/ph/hz	r.p.m.	kg.	cm	
COMPRESSORI TRIFASE CARRELLATI - PORTABLE THREE PHASES COMPRESSORS															
91054	EC 200/5,5T	10	145	2	5,5	4	606	21,4	36,4	200 C	400/3/50	1400	139	145x46x94	
91055	EC 270/5,5T									270 C	400/3/50		155	155x57x112	
91056	EC 500/5,5T									500 C	400/3/50		215	203x68x131	
COMPRESSORI TRIFASE FISSI - FIXED THREE PHASES COMPRESSORS															
91060	EC 200/5,5T	10	145	2	5,5	4	606	21,4	36,4	200 F	400/3/50	1400	139	145x46x94	
91061	EC 270/5,5T									270 F	400/3/50		155	155x57x112	
91062	EC 500/5,5T									500 F	400/3/50		215	203x68x131	

serie/series:

EASY-C

**QUALITY
MADE IN ITALY**

COMPRESSORI PROFESSIONALI - MONOSTADIO TRASMISSIONE A CINGHIA - LUBRIFICATI
OIL - LUBRIFICATED SINGLE-STAGE PROFESSIONAL COMPRESSORS WITH BELT DRIVE

Max 75 dB(A)



EC 150V/3 M



EC 270V/7,5 T

EC VERTICAL SERIES

Codice	Modello		Pressione		N. Cilindri	Potenza Nominale Motore		Aria Aspirata			Serb.	Voltaggio	Giri/min	Peso	Dimensione Imballo
Cod.	Model		Pressure		N. Cilinders	Nominal Motor Rating		Air Displacement			Tank	Voltage	r.p.m.	Weight	Packaging Dimension
-	Series	Comp. Pump	bar	p.s.i.	Cil.	Hp	kW	lt./min.	CFM	m3/h	lt.	Volt/ph/hz	r.p.m.	kg.	cm
COMPRESSORI VERTICALI MONOFASE FISSI - VERTICAL FIXED SINGLE PHASES COMPRESSORS															
91096	EC 150/3M	NG 3	10	145	2	3	2,2	315	11,1	18,9	150V	230/1/50	1400	94	50x70x148
COMPRESSORI VERTICALI TRIFASE FISSI - VERTICAL FIXED THREE PHASES COMPRESSORS															
91096.1	EC 150/3T	NG 3	10	145	2	3	2,2	315	11,1	18,9	150V	400/3/50	1400	97	50x70x148
91097	EC 150/4T	NG 4				4	3	541	19,1	32,5	150V	400/3/50		165	50x70x148

GRUPPI POMPANTI A CINGHIA MONOSTADIO E BISTADIO
BELT DRIVEN SINGLE AND TWO-STAGE PUMPS

- Adatti ad un servizio gravoso e continuo
- Potenti ed affidabili
- Elevate prestazioni
- Lunga durata
- Assenza di vibrazioni
- Basse velocità di rotazione
- Da 2 a 20 HP
- Fino a 14 bar di pressione

- Heavy Duty service -
- Strong and Reliable -
- High performances -
- Long life -
- Low vibrations -
- Low speed -
- From 2 to 20 HP -
- Max 14 bar -



PIASTRA VALVOLE

- Piastra in ghisa: robusta, affidabile, a lunga durata
- Camere di passaggio aria sovra dimensionate per una ideale temperatura di lavorazione e per ottenere elevate prestazioni.

VALVES PLATES

- Cast Iron, strong reliable, longlife
- Oversized air pasage chambre for better temperature and High performances.

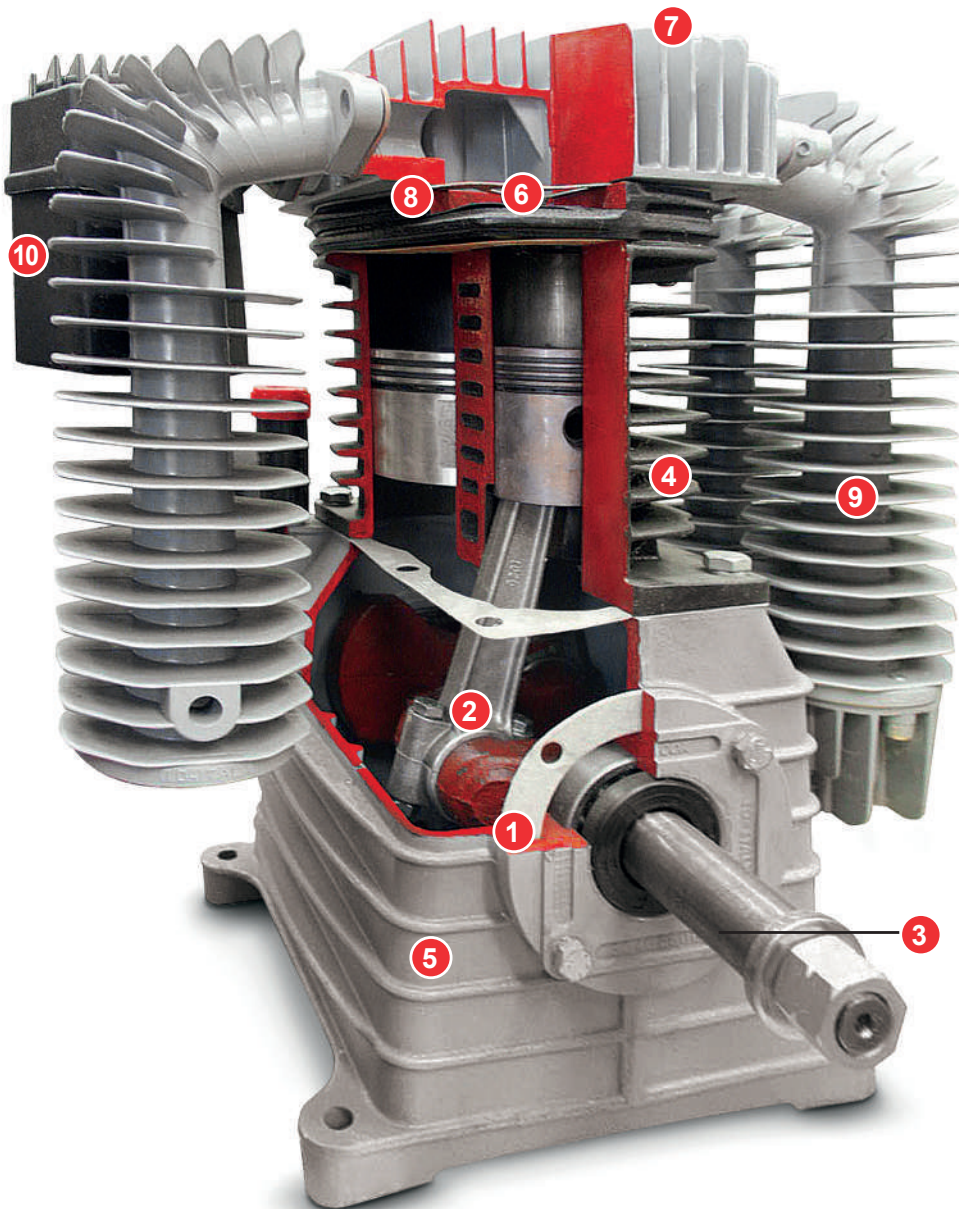

**I PUNTI DI FORZA DEI GRUPPI K
PUMPS K STRENGTH POINTS**

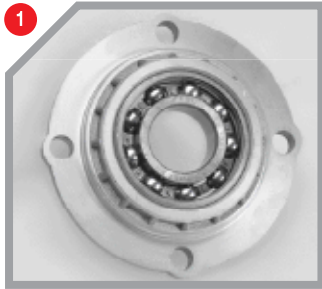

CUSCINETTI

Cuscinetti volventi di alta qualità sono la base per garantire un servizio continuo e gravoso in tutte le condizioni di lavoro.

BEARINGS

High quality beall bearings are the basis for ensuring a continuous service in all working conditions.



ALBERO A GOMITO E BIELLE

- Albero a gomito bilanciato elettronicamente: nessuna vibrazione
- Bielle dotate di bronzine con materiale a basso attrito assicurano alta efficienza e riduzione dell'usura.

CRANKSHAFT AND CONNECTING ROD

- Crankshaft balanced with electronic equipment: no vibration
- Con-rod with low friction bushes to assure high efficiency and reduced wear.



VOLANI

Il profilo delle pale del volano è progettato per assicurare un elevato raffreddamento.

FLYWHEELS

The profile of the blades of the flywheel are designed to ensure a high cooling.



CILINDRI

- In ghisa: affidabili, resistenti
- Speciali lavorazioni assicurano un basso consumo di olio.

CYLINDERS

- In cast iron: strong, reliable, heavy duty
- Special machining to assure low oil consumption.



CARTER

- Grande capienza di olio per una lunga autonomia
- Verniciatura interna con resina che impedisce le perdite d'olio

CRANKCASE

- Assenza di vibrazioni: fusione in alluminio con grandi spessori.
- High capacity of oil tank for longer autonomy
- Internal painting with resin against oil losses
- No vibrations: big thickness of casting.

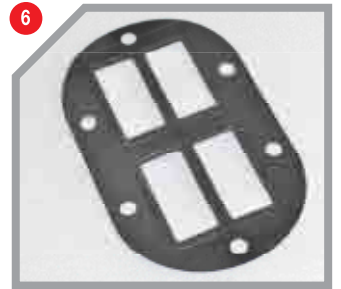

GUARNIZIONI VALVOLE

- In acciaio inox con riporto di elastomeri: garantiscono una perfetta tenuta e una lunga durata in durissime condizioni.

VALVES GASKET

- In stainless steel with carryover of elastomers: assure perfect seal and long life in a very harsh conditions.



TESTA

- In alluminio pressofuso per una migliore dissipazione di calore, con ampie alettature per il massimo raffreddamento.

HEAD

- Alu die casting for a better dissipation of heat, with large fins for maximum cooling.



COLLETTORI

- In alluminio pressofuso per una migliore dissipazione di calore
- Ampie alettature per il massimo raffreddamento.

AFTER COOLER

- Alu die casting for a better dissipation of heat
- Large fins for maximum cooling.



FILTRO

- Sistema a labirinto per ridurre il rumore
- Grandi elementi filtranti
- Lunga durata.

FILTER

- Labyrinth system to reduce noise
- Large Dust filter elements
- Long life.



serie/series:

INDUSTRIAL

PR

COMPRESSORI INDUSTRIALI - MONOSTADIO - TRASMISSIONE A CINGHIA - LUBRIFICATI
OIL - LUBRIFICATED SINGLE-STAGE INDUSTRIAL COMPRESSORS WITH BELT DRIVE

**QUALITY
MADE IN ITALY**



PR 100/2M

K SERIES



Testata a basso numero di giri
Comp. pump with low rpm

PR SERIES - 2 HP

Max 76 dB(A)

Codice	Modello	Pressione		N. Cilindri	Potenza Nominale Motore		Aria Aspirata			Serb.	Voltaggio	Giri/min	Peso	Dimensione Imballo
Cod.	Model	Pressure		N. Cylinders	Nominal Motor Rating		Air Displacement			Tank	Voltage	r.p.m.	Weight	Packaging Dimension
-	Series	bar	p.s.i.	Cil.	Hp	kW	lt./min.	CFM	m3/h	lt.	Volt/ph/hz	r.p.m.	kg.	cm
COMPRESSORI CARRELLATI - PORTABLE COMPRESSORS														
20302	PR 50/2M	10	145	2	2	1,5	260	9,2	15,6	50 C	230/1/50	1180	54	85x38x73
20402	PR 100/2M									100 C	230/1/50		69	100x40x80
20303	PR 50/2T	10	145	2	2	1,5	260	9,2	15,6	50 C	400/3/50	1180	54	85x38x73
20403	PR 100/2T									100 C	400/3/50		69	100x40x80

*SC: senza collettore / without aftercooler

serie/series:

INDUSTRIAL

PR

COMPRESSORI INDUSTRIALI - MONOSTADIO - TRASMISSIONE A CINGHIA - LUBRIFICATI
OIL - LUBRICATED SINGLE-STAGE INDUSTRIAL COMPRESSORS WITH BELT DRIVE

**QUALITY
MADE IN ITALY**



K SERIES



Testata a basso numero di giri
Comp. pump with low rpm

PR SERIES - 3 HP

Max 75 dB(A)

Codice	Modello	Pressione		N. Cilindri	Potenza Nominale Motore		Aria Aspirata			Serb.	Voltaggio	Giri/min	Peso	Dimensione Imballo
Cod.	Model	Pressure		N. Cilinders	Nominal Motor Rating		Air Displacement			Tank	Voltage	r.p.m.	Weight	Packaging Dimension
-	Series	bar	p.s.i.	Cil.	Hp	kW	lt./min.	CFM	m3/h	lt.	Volt/ph/hz	r.p.m.	kg.	cm
COMPRESSORI CARRELLATI CON TESTATA "K" - PORTABLE COMPRESSORS WITH "K" COMPRESSOR PUMP														
20304	PR 50/3M									50 C	230/1/50		67	85x38x73
20404	PR 100/3M									100 C	230/1/50		73	100x40x80
20504	PR 150/3M	10	145	2	3	2,2	400	14,1	24	150 C	230/1/50	1250	82	132x45x92
20604	PR 200/3M									200 C	230/1/50		96	145x50x107
20704	PR 270/3M									270 C	230/1/50		113	155x57x118
20305	PR 50/3T									50 C	400/3/50		67	85x38x73
20405	PR 100/3T									100 C	400/3/50		73	100x40x80
20505	PR 150/3T	10	145	2	3	2,2	400	14,1	24	150 C	400/3/50	1250	82	132x45x92
20605	PR 200/3T									200 C	400/3/50		96	145x50x107
20705	PR 270/3T									270 C	400/3/50		113	155x57x118

serie/series:

INDUSTRIAL

PR

COMPRESSORI INDUSTRIALI - MONOSTADIO - TRASMISSIONE A CINGHIA - LUBRIFICATI
OIL - LUBRICATED SINGLE-STAGE INDUSTRIAL COMPRESSORS WITH BELT DRIVE

**QUALITY
MADE IN ITALY**

K SERIES



Testata a basso numero di giri
Comp. pump with low rpm



PR 200/4T

Max 74 dB(A)

PR SERIES - 4 HP

Codice	Modello	Pressione		N. Cilindri	Potenza Nominale Motore		Aria Aspirata			Serb.	Voltaggio	Giri/min	Peso	Dimensione Imballo
Cod.	Model	Pressure		N. Cilinders	Nominal Motor Rating		Air Displacement			Tank	Voltage	r.p.m.	Weight	Packaging Dimension
-	Series	bar	p.s.i.	Cil.	Hp	kW	lt./min.	CFM	m3/h	lt.	Volt/ph/hz	r.p.m.	kg.	cm
COMPRESSORI CARRELLATI CON TESTATA "K" - PORTABLE COMPRESSORS WITH "K" COMPRESSOR PUMP														
20406	PR 100/4T	10	145	2	4	3	540	19,1	32,4	100 C	400/3/50	1100	73	100x40x80
20506	PR 150/4T									150 C	400/3/50		82	132x45x92
20606	PR 200/4T									200 C	400/3/50		96	145x50x107
20706	PR 270/4T									270 C	400/3/50		113	155x57x118
COMPRESSORI FISSI CON TESTATA "K" - FIXED COMPRESSORS WITH "K" COMPRESSOR PUMP														
21406	PR 100/4T	10	145	2	4	3	540	19,1	32,4	100 F	400/3/50	1100	73	100x40x80
21506	PR 150/4T									150 F	400/3/50		82	132x45x92
21606	PR 200/4T									200 F	400/3/50		96	145x50x107
21706	PR 270/4T									270 F	400/3/50		113	155x57x118

serie/series:

INDUSTRIAL

PR

COMPRESSORI INDUSTRIALI - BISTADIO - TRASMISSIONE A CINGHIA - LUBRIFICATI
OIL - LUBRICATED DOUBLE-STAGE INDUSTRIAL COMPRESSORS WITH BELT DRIVE

**QUALITY
MADE IN ITALY**

Max 81 dB(A)



PR 270/5,5T

K SERIES

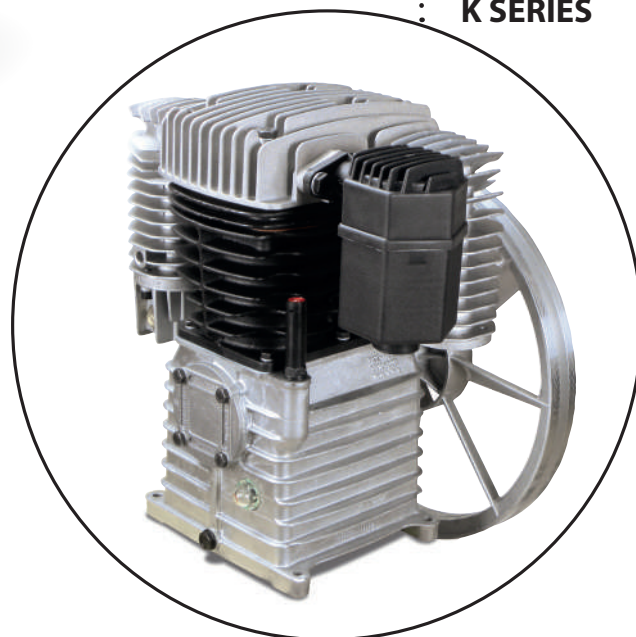

Testata a basso numero di giri
Comp. pump with low rpm

PR SERIES - 5,5 HP

Codice	Modello	Pressione		N. Cilindri	Potenza Nominale Motore			Aria Aspirata			Serb.	Voltaggio	Giri/min	Peso	Dimensione Imballo
Cod.	Model	Pressure		N. Cilinders	Nominal Motor Rating			Air Displacement			Tank	Voltage	r.p.m.	Weight	Packaging Dimension
-	Series	bar	p.s.i.	Cil.	Hp	kW	lt./min.	CFM	m3/h	lt.	Volt/ph/hz	r.p.m.	kg.	cm	
COMPRESSORI CARRELLATI CON TESTATA - PORTABLE COMPRESSORS WITH COMPRESSOR PUMP															
20708	PR 270/5,5T	10	145	2	5,5	4	662	23,4	39,7	270 C	400/3/50	1290	170	155X57X118	
20808	PR 500/5,5									500 C	400/3/50		215	203X70X131	
COMPRESSORI FISSI CON TESTATA - FIXED COMPRESSORS WITH COMPRESSOR PUMP															
21708	PR 270/5,5T	10	145	2	5,5	4	662	23,4	39,7	270 F	400/3/50	1290	170	155X57X118	
21808	PR 500/5,5									500 F	400/3/50		215	203X70X131	
21808	PR 500/5,5 ST	10	145	2	5,5	4	662	23,4	39,7	500 F	400/3/50	1290	225	203X70X131	

serie/series:

INDUSTRIAL

PR

COMPRESSORI INDUSTRIALI - BISTADIO - TRASMISSIONE A CINGHIA - LUBRIFICATI
OIL - LUBRICATED DOUBLE-STAGE INDUSTRIAL COMPRESSORS WITH BELT DRIVE

**QUALITY
MADE IN ITALY**

Max 81 dB(A)



K SERIES



Testata a basso numero di giri
Comp. pump with low rpm

PR SERIES - 7,5 HP

Codice	Modello	Pressione		N. Cilindri	Potenza Nominale Motore		Aria Aspirata			Serb.	Voltaggio	Giri/min	Peso	Dimensione Imballo
Cod.	Model	Pressure		N. Cylinders	Nominal Motor Rating		Air Displacement			Tank	Voltage	r.p.m.	Weight	Packaging Dimension
-	Series	bar	p.s.i.	Cil.	Hp	kW	lt./min.	CFM	m3/h	lt.	Volt/ph/hz	r.p.m.	kg.	cm
COMPRESSORI CARRELLATI CON TESTATA - PORTABLE COMPRESSORS WITH COMPRESSOR PUMP														
20709	PR 270/7,5T	10	145	2	7,5	5,5	872	31	52,3	270 C	400/3/50	1200	185	155X57X118
20809	PR 500/7,5T									500 C	400/3/50		215	203X70X131
COMPRESSORI FISSI CON TESTATA - FIXED COMPRESSORS WITH COMPRESSOR PUMP														
21709	PR 270/7,5T	10	145	2	7,5	5,5	872	31	52,3	270 F	400/3/50	1200	185	155X57X118
21809	PR 500/7,5T									500 F	400/3/50		215	203X70X131
21709	PR 270/7,5T ST	10	145	2	7,5	5,5	872	31	52,3	270 F	400/3/50	1200	200	155X57X118
21809	PR 500/7,5T ST									500 F	400/3/50		230	203X70X131

serie/series:

INDUSTRIAL

PR

COMPRESSORI INDUSTRIALI - BISTADIO - TRASMISSIONE A CINGHIA - LUBRIFICATI OIL - LUBRICATED DOUBLE-STAGE INDUSTRIAL COMPRESSORS WITH BELT DRIVE

**QUALITY
MADE IN ITALY**

Max 81 dB(A)



PR 500F/10T



K SERIES

Testata a basso numero di giri
Comp. pump with low rpm

PR SERIES - 10 HP

Codice	Modello	Pressione		N. Cilindri	Potenza Nominale Motore		Aria Aspirata			Serb.	Voltaggio	Giri/min	Peso	Dimensione Imballo
Cod.	Model	Pressure		N. Cylinders	Nominal Motor Rating		Air Displacement			Tank	Voltage	r.p.m.	Weight	Packaging Dimension
-	Series	bar	p.s.i.	Cil.	Hp	kW	lt./min.	CFM	m3/h	lt.	Volt/ph/hz	r.p.m.	kg.	cm
COMPRESSORI CARRELLATI CON TESTATA - PORTABLE COMPRESSORS WITH COMPRESSOR PUMP														
20710	PR 270/10T	10	145	2	10	7,5	1074	38	64,4	270 C	400/3/50	1000	215	155X57X118
20810	PR 500/10T									500 C	400/3/50		266	203X70X131
COMPRESSORI FISSI CON TESTATA - FIXED COMPRESSORS WITH COMPRESSOR PUMP														
21710	PR 270/10T	10	145	2	10	7,5	1074	38	64,4	270 F	400/3/50	1000	215	155X57X118
21810	PR 500/10T									500 F	400/3/50		266	203X70X131
21910	PR 900/10T									900 F	400/3/50		371	212x85x161
21710	PR 270/10T ST	10	145	2	10	7,5	1074	38	64,4	270 F	400/3/50	1000	230	155X57X118
21810	PR 500/10T ST									500 F	400/3/50		281	203X70X131
21910	PR 900/10T ST									900 F	400/3/50		386	212x85x161

serie/series:

INDUSTRIAL

PR

COMPRESSORI INDUSTRIALI - BISTADIO - TRASMISSIONE A CINGHIA - LUBRIFICATI
OIL - LUBRICATED DOUBLE-STAGE INDUSTRIAL COMPRESSORS WITH BELT DRIVE

**QUALITY
MADE IN ITALY**



PR 500F/15T

Max 81 dB(A)

Codice	Modello	Pressione		N. Cilindri	Potenza Nominale Motore		Aria Aspirata			Serb.	Voltaggio	Giri/min	Peso	Dimensione Imballo
Cod.	Model	Pressure		N. Cylinders	Nominal Motor Rating		Air Displacement			Tank	Voltage	r.p.m.	Weight	Packaging Dimension
-	Series	bar	p.s.i.	Cil.	Hp	kW	lt./min.	CFM	m3/h	lt.	Volt/ph/hz	r.p.m.	kg.	cm
COMPRESSORI FISSI CON TESTATA - FIXED COMPRESSORS WITH COMPRESSOR PUMP														
21711	PR 270/15T	10	145	4	15	11	1505	53,2	90,3	270 F	400/3/50	1400	226	155X57X118
21811	PR 500/15T									500 F	400/3/50		275	203X70X131
21911	PR 900/15T									900 F	400/3/50		381	212x85x161
21711	PR 270/15T ST	10	145	4	15	11	1505	53,2	90,3	270 F	400/3/50	1400	245	155X57X118
21811	PR 500/15T ST									500 F	400/3/50		291	203X70X131
21911	PR 900/15T ST									900 F	400/3/50		396	212x85x161

serie/series:

INDUSTRIAL

PR TANDEM

COMPRESSORI INDUSTRIALI - BISTADIO - TRASMISSIONE A CINGHIA - LUBRIFICATI
OIL - LUBRICATED DOUBLE-STAGE INDUSTRIAL COMPRESSORS WITH BELT DRIVE

**QUALITY
MADE IN ITALY**



PR 900/10 TTD

K SERIES



Testata a basso numero di giri
Comp. pump with low rpm



PR 900/15 TTD



PR SERIES - TANDEM

Max 81 dB(A)

Codice	Modello	Pressione		N. Cilindri	Potenza Nominale Motore		Aria Aspirata			Serb.	Voltaggio	Giri/min	Peso	Dimensione Imballo
Cod.	Model	Pressure		N. Cylinders	Nominal Motor Rating		Air Displacement			Tank	Voltage	r.p.m.	Weight	Packaging Dimension
-	Series	bar	p.s.i.	Cil.	Hp	kW	lt./min.	CFM	m3/h	lt.	Volt/ph/hz	r.p.m.	kg.	cm
COMPRESSORI FISSI CON TESTATA "K" - FIXED COMPRESSORS WITH "K" COMPRESSOR PUMP														
21812	PR 500/5,5TTD	10	145	2	5,5+5,5	4+4	1324	46,8	79,4	500 F	400/3/50	1290	400	203X70X131
21813	PR 500/7,5TTD	10	145	2	7,5+7,5	5,5+5,5	1744	62	104,6	500 F	400/3/50	1200	410	203X70X131
21913	PR 900/7,5TTD				7,5+7,5	5,5+5,5				900 F	400/3/50		566	212x85x161
21814	PR 500/10TTD	10	145	2	10+10	7,5+7,5	2148	76	128,8	500 F	400/3/50	1000	430	203X70X131
21914	PR 900/10TTD				10+10	7,5+7,5				900 F	400/3/50		586	212x85x161

serie/series:

INDUSTRIAL

PR VERTICAL

COMPRESSORI INDUSTRIALI - BISTADIO - TRASMISSIONE A CINGHIA - LUBRIFICATI
OIL - LUBRIFICATED DOUBLE-STAGE INDUSTRIAL COMPRESSORS WITH BELT DRIVE

**QUALITY
MADE IN ITALY**



PR 270V/7,5T

K SERIES

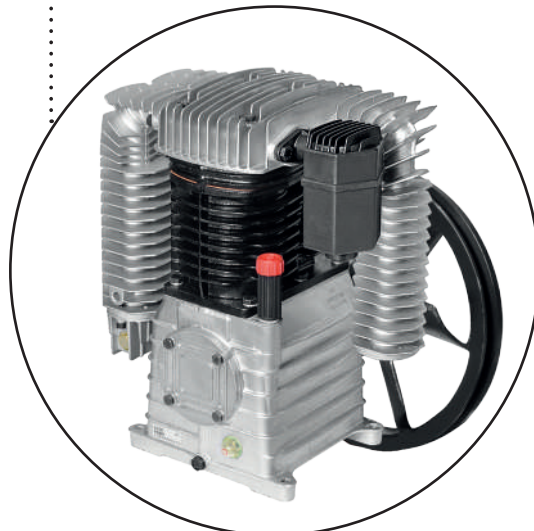

Testata a basso numero di giri
Comp. pump with low rpm

PR SERIES - VERTICAL

Max 81 dB(A)

Codice	Modello	Pressione		N. Cilindri	Potenza Nominale Motore		Aria Aspirata			Serb.	Voltaggio	Giri/min	Peso	Dimensione Imballo
Cod.	Model	Pressure		N. Cylinders	Nominal Motor Rating		Air Displacement			Tank	Voltage	r.p.m.	Weight	Packaging Dimension
-	Series	bar	p.s.i.	Cil.	Hp	kW	lt./min.	CFM	m3/h	lt.	Volt/ph/hz	r.p.m.	kg.	cm
COMPRESSORI FISSI VERTICALI CON TESTATA - VERTICAL FIXED COMPRESSORS WITH COMPRESSOR PUMP														
22008	PR 270V/5,5T	10	145	2	5,5	4	662	23,4	39,7	270 V	400/3/50	1290	170	90x63x195
22009	PR 270V/7,5T	10	145	2	7,5	5,5	872	31	52,3	270 V	400/3/50	1200	185	90x63x195
22009	PR 270V/7,5T ST									270 V	400/3/50	200	90x63x195	
22010	PR 270V/10T	10	145	2	10	7,5	1074	38	64,4	270 V	400/3/50	1000	215	90x63x195
22010	PR 270V/10T ST									270 V	400/3/50		230	90x63x195

serie/series:

INDUSTRIAL

PRB

COMPRESSORI INDUSTRIALI - BISTADIO - TRASMISSIONE A CINGHIA - LUBRIFICATI
OIL - LUBRICATED DOUBLE-STAGE INDUSTRIAL COMPRESSORS WITH BELT DRIVE

**QUALITY
MADE IN ITALY**



PRB 7,5 T

K SERIES



Testata a basso numero di giri
Comp. pump with low rpm

Max 81 dB(A)

PR SERIES - BASE

Codice	Modello	Pressione		N. Cilindri	Potenza Nominale Motore		Aria Aspirata			Serb.	Voltaggio	Giri/min	Peso	Dimensione Imballo
Cod.	Model	Pressure		N. Cylinders	Nominal Motor Rating		Air Displacement			Tank	Voltage	r.p.m.	Weight	Packaging Dimension
-	Series	bar	p.s.i.	Cil.	Hp	kW	lt./min.	CFM	m3/h	lt.	Volt/ph/hz	r.p.m.	kg.	cm
BASAMENTO CON TESTATA "K" - BASE WITH "K" COMPRESSOR PUMP														
21008	PRB 5,5T	10	145	2	5,5	4	662	23,4	39,7	-	400/3/50	1290	69	105x55x65
21009	PRB 7,5T	10	145	2	7,5	5,5	872	31	52,3	-	400/3/50	1200	79	105x55x65
21009	PRB 7,5T ST									-			85	
21010	PRB 10T	10	145	2	10	7,5	1074	38	64,4	-	400/3/50	1000	114	105x55x65
21010	PRB 10T ST									-			129	

serie/series:

INDUSTRIAL

PR 15 BAR

COMPRESSORI INDUSTRIALI - BISTADIO - TRASMISSIONE A CINGHIA - LUBRIFICATI
OIL - LUBRICATED DOUBLE-STAGE INDUSTRIAL COMPRESSORS WITH BELT DRIVE

**QUALITY
MADE IN ITALY**



PR 270/10-15B

PR SERIES - 15 BAR

Max 81 dB(A)

Codice	Modello	Pressione		N. Cilindri	Potenza Nominale Motore			Aria Aspirata			Serb.	Voltaggio	Giri/min	Peso	Dimensione Imballo
Cod.	Model	Pressure		N. Cylinders	Nominal Motor Rating			Air Displacement			Tank	Voltage	r.p.m.	Weight	Packaging Dimension
-	Series	bar	p.s.i.	Cil.	Hp	kW	lt./min.	CFM	m3/h	lt.	Volt/ph/hz	r.p.m.	kg.	cm	
COMPRESSORI A 15bar FISSI CON TESTATA - 15bar FIXED COMPRESSORS WITH COMPRESSOR PUMP															
21708	PR 270/5,5T 15B	10	145	2	5,5	4	432	15,2	25,9	270 F	400/3/50	1000	150	155x57x120	
21808	PR 500/5,5T 15B									500 F	400/3/50		212	203x68x131	
21709	PR 270/7,5T 15B	10	145	2	7,5	5,5	570	20,1	34,2	270 F	400/3/50	1000	153	155x57x120	
21809	PR 500/7,5T 15B									500 F	400/3/50		213	203x68x131	
21710	PR 270/10T 15B	10	145	4	10	7,5	942	33,2	56,5	270 F	400/3/50	1000	186	155x57x120	
21810	PR 500/10T 15B									500 F	400/3/50		246	203x68x131	
21710	PR 270/10T 15B ST	10	145	4	10	7,5	942	33,2	56,5	270 F	400/3/50	1000	209	155x57x120	
21810	PR 500/10T 15B ST									500 F	400/3/50		263	203x68x131	
21711	PR 270/15T 15B	10	145	4	15	11	1140	40,3	68,4	270 F	400/3/50	1000	232	155x57x120	
21811	PR 500/15T 15B									500 F	400/3/50		280	203x68x131	
21811	PR 500/15T 15B ST	10	145	4	15	11	1140	40,3	68,4	500 F	400/3/50	1000	263	203x68x131	

SILENT-LS Max 68 dB(A)



serie/series:

INDUSTRIAL

SILENT LS

COMPRESSORI INDUSTRIALI SILENZIATI - BISTADIO - TRASMISSIONE A CINGHIA - LUBRIFICATI
SILENT DOUBLE-STAGE INDUSTRIAL COMPRESSORS WITH BELT DRIVE - OIL LUBRIFICATED

**QUALITY
MADE IN ITALY**



 **Max 68 dB(A)**

Compressore a basso numero di giri
Compressor with low rpm

Codice	Modello	Pressione		N. Cilindri	Potenza Nominale Motore		Aria Aspirata			Serb.	Voltaggio	Giri/min	Peso	Dimensione Imballo
Cod.	Model	Pressure		N. Cylinders	Nominal Motor Rating		Air Displacement			Tank	Voltage	r.p.m.	Weight	Packaging Dimension
-	Series	bar	p.s.i.	Cil.	Hp	kW	lt./min.	CFM	m3/h	lt.	Volt/ph/hz	r.p.m.	kg.	cm
COMPRESSORI SILENZIATI CARRELLATI - SILENT COMPRESSORS WITH WHEELS														
44500	LS 250 - 90	10	145	2	2	1,5	260	9,2	15,6	90	230/1/50	1180	115	40x100x110
44501	LS 350 M - 90	10	145	2	3	2,2	400	14,1	24	90	230/1/50	1250	120	40x100x110
44502	LS 350 T - 90	10	145	2	3	2,2	400	14,1	24	90	400/3/50	1250	120	40x100x110
44503	LS 450 - 90	10	145	2	4	3	540	19,1	32,4	90	400/3/50	1110	145	40x100x110
COMPRESSORI SILENZIATI FISSI - SILENT FIXED COMPRESSORS														
44600	LS 250 - 200	10	145	2	2	1,5	260	9,2	15,6	200	230/1/50	1180	180	50x120x122
44601	LS 350 M - 200	10	145	2	3	2,2	400	14,1	24	200	230/1/50	1250	185	50x120x122
44602	LS 350 T - 200	10	145	2	3	2,2	400	14,1	24	200	400/3/50	1250	185	50x120x122
44603	LS 450 - 200	10	145	2	4	3	540	19,1	32,4	200	400/3/50	1110	200	50x120x122

serie/series:

INDUSTRIAL

SILENT LS

COMPRESSORI INDUSTRIALI SILENZIATI - BISTADIO - TRASMISSIONE A CINGHIA - LUBRIFICATI
 SILENT DOUBLE-STAGE INDUSTRIAL COMPRESSORS WITH BELT DRIVE - OIL LUBRIFICATED

**QUALITY
 MADE IN ITALY**



LS 1000



Max 68 dB(A)

Compressore a basso numero di giri
 Compressor with low rpm

Codice	Modello	Pressione		N. Cilindri	Potenza Nominale Motore		Aria Aspirata			Serb.	Voltaggio	Giri/min	Peso	Dimensione Imballo
Cod.	Model	Pressure		N. Cylinders	Nominal Motor Rating		Air Displacement			Tank	Voltage	r.p.m.	Weight	Packaging Dimension
-	Series	bar	p.s.i.	Cil.	Hp	kW	lt./min.	CFM	m3/h	lt.	Volt/ph/hz	r.p.m.	kg.	cm
COMPRESSORI SILENZIATI CON TESTATA - SILENT COMPRESSORS WITH COMPRESSOR PUMP														
44006.0	LS 450	10	145	2	4	3	540	19,1	32,4	-	400/3/50	1400	170	120x70x100
44007.4	LS 550	10	145	2	5,5	4	662	23,4	39,7	-	400/3/50	1290	181	120x70x100
44008.2	LS 750	10	145	2	7,5	5,5	872	31	52,4	-	400/3/50	1200	234	120x70x100
44009.2	LS 750 ST									-			240	
44010.0	LS 1000	10	145	2	10	7,5	1074	38	64,4	-	400/3/50	1000	253	120x70x100
44011.3	LS 1000 ST									-			259	

serie/series:

INDUSTRIAL

SILENT LS

COMPRESSORI INDUSTRIALI SILENZIATI - BISTADIO - TRASMISSIONE A CINGHIA - LUBRIFICATI
SILENT DOUBLE-STAGE INDUSTRIAL COMPRESSORS WITH BELT DRIVE - OIL LUBRIFICATED

**QUALITY
MADE IN ITALY**

Max 68 dB(A)

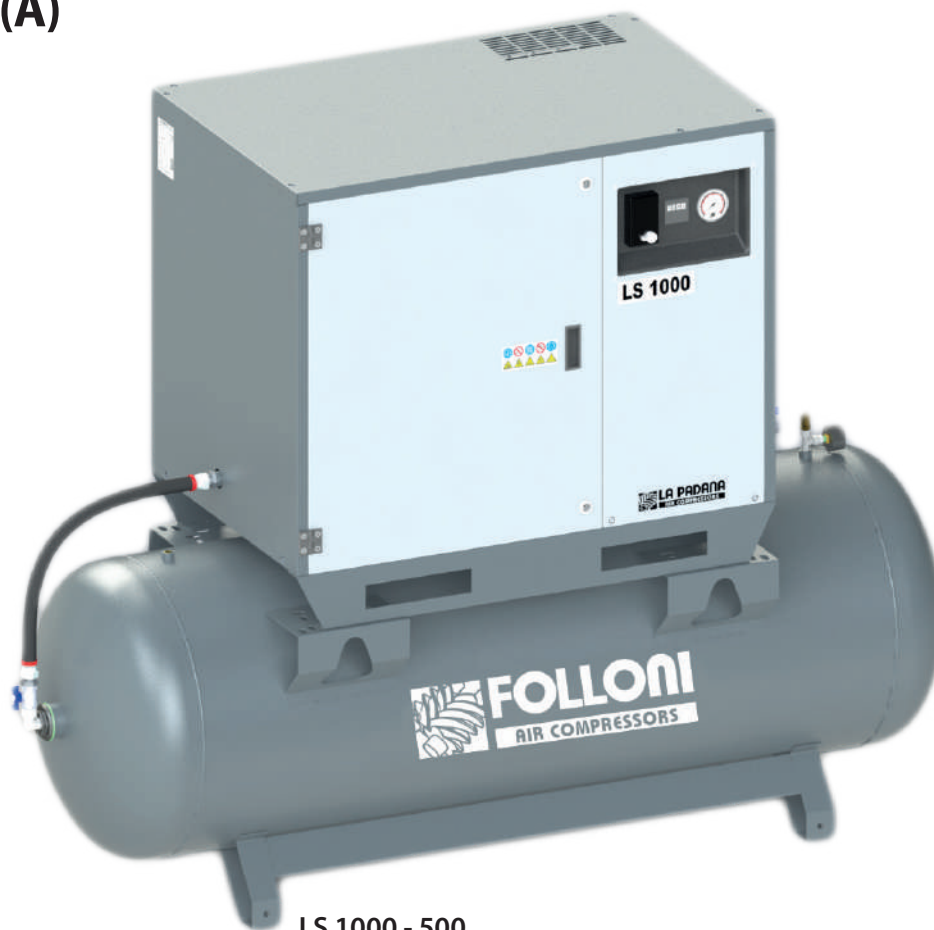

LS 1000 - 500

Compressore a basso numero di giri
Compressor with low rpm

Codice	Modello	Pressione		N. Cilindri	Potenza Nominale Motore		Aria Aspirata			Serb.	Voltaggio	Giri/min	Peso	Dimensione Imballo
Cod.	Model	Pressure		N. Cylinders	Nominal Motor Rating		Air Displacement			Tank	Voltage	r.p.m.	Weight	Packaging Dimension
-	Series	bar	p.s.i.	Cil.	Hp	kW	lt./min.	CFM	m3/h	lt.	Volt/ph/hz	r.p.m.	kg.	cm
COMPRESSORI SILENZIATI CON SERBATOIO E CON TESTATA - SILENT COMPRESSORS WITH AIR TANK AND COMPRESSOR PUMP														
44106.0	LS 450 - 270	10	145	2	4	3	540	19,1	32,4	270 F	400/3/50	1400	248	155x73x165
44107.4	LS 550 - 270	10	145	2	5,5	4	662	23,4	39,7	270 F	400/3/50	1290	248	155x73x165
44207.4	LS 550 - 500									500 F	400/3/50			
44108.2	LS 750 - 270	10	145	2	7,5	5,5	872	31	52,4	270 F	400/3/50	1200	301	155x73x165
44109.0	LS 750 - 270 ST									270 F	400/3/50			
44208.0	LS 750 - 500	10	145	2	7,5	5,5	872	31	52,4	500 F	400/3/50	1200	379	195x73x173
44209.0	LS 750 - 500 ST									500 F	400/3/50			
44110.2	LS 1000 - 270	10	145	2	10	7,5	1074	38	64,4	270 F	400/3/50	1000	320	155x73x165
44111.0	LS 1000 - 270 ST									270 F	400/3/50			
44210.0	LS 1000 - 500	10	145	2	10	7,5	1074	38	64,4	500 F	400/3/50	1000	417	195x73x173
44211.0	LS 1000 - 500 ST									500 F	400/3/50			

serie/series:

INDUSTRIAL

SILENT LS

COMPRESSORI INDUSTRIALI SILENZIATI - BISTADIO - TRASMISSIONE A CINGHIA - LUBRIFICATI
SILENT DOUBLE-STAGE INDUSTRIAL COMPRESSORS WITH BELT DRIVE - OIL LUBRIFICATED

**QUALITY
MADE IN ITALY**

Max 68 dB(A)



Compressore a basso numero di giri
Compressor with low rpm

Codice	Modello	Pressione		N. Cilindri	Potenza Nominale Motore		Aria Aspirata			Serb.	Voltaggio	Giri/min	Peso	Dimensione Imballo
Cod.	Model	Pressure		N. Cylinders	Nominal Motor Rating		Air Displacement			Tank	Voltage	r.p.m.	Weight	Packaging Dimension
-	Series	bar	p.s.i.	Cil.	Hp	kW	lt./min.	CFM	m3/h	lt.	Volt/ph/hz	r.p.m.	kg.	cm
COMPRESSORI SILENZIATI CON SERBATOIO, ESSICCATORE E CON TESTATA - SILENT COMPRESSOR WITH AIR TANK, DRYER AND COMPRESSOR PUMP														
44306.0	LS 450 - 270 E	10	145	2	4	3	540	19,1	32,4	270 F	400/3/50	1400	273	155x73x165
44307.4	LS 550 - 270 E	10	145	2	5,5	4	662	23,4	39,7	270 F	400/3/50	1290	273	155x73x165
44407.4	LS 550 - 500 E									500 F	400/3/50			
44308.0	LS 750 - 270 E	10	145	2	7,5	5,5	872	31	52,4	270 F	400/3/50	1200	326	155x73x165
44309.2	LS 750 - 270 ST E									270 F	400/3/50			
44408.1	LS 750 - 500 E	10	145	2	7,5	5,5	872	31	52,4	500 F	400/3/50	1200	404	195x73x173
44409.0	LS 750 - 500 ST E									500 F	400/3/50			
44310.0	LS 1000 - 270 E	10	145	2	10	7,5	1074	38	64,4	270 F	400/3/50	1000	345	155x73x165
44311.0	LS 1000 - 270 ST E									270 F	400/3/50			
44410.0	LS 1000 - 500 E	10	145	2	10	7,5	1074	38	64,4	500 F	400/3/50	1000	442	195x73x173
44411.0	LS 1000 - 500 ST E									500 F	400/3/50			

serie/series:

INDUSTRIAL SILENT LS – 15 BAR

COMPRESSORI INDUSTRIALI SILENZIATI - BISTADIO - TRASMISSIONE A CINGHIA - LUBRIFICATI
SILENT DOUBLE-STAGE INDUSTRIAL COMPRESSORS WITH BELT DRIVE - OIL LUBRICATED

**QUALITY
MADE IN ITALY**



LS 1000



 **Max 68 dB(A)**

Codice	Modello	Pressione		N. Cilindri	Potenza Nominale Motore		Aria Aspirata			Serb.	Voltaggio	Giri/min	Peso	Dimensione Imballo
Cod.	Model	Pressure		N. Cylinders	Nominal Motor Rating		Air Displacement			Tank	Voltage	r.p.m.	Weight	Packaging Dimension
-	Series	bar	p.s.i.	Cil.	Hp	kW	lt./min.	CFM	m3/h	lt.	Volt/ph/hz	r.p.m.	kg.	cm
COMPRESSORI SILENZIATI CON TESTATA "NG" - SILENT COMPRESSORS WITH "NG" COMPRESSOR PUMP														
44007.2	LS 550	15	218	2	5,5	4	432	15,2	25,9	-	400/3/50	1000	181	120x70x100
44008.1	LS 750	15	218	2	7,5	5,5	570	20,1	34,2	-	400/3/50	1000	234	120x70x100
44009.1	LS 750 ST												240	120x70x100
44010.1	LS 1000	15	218	2	10	7,5	942	33,2	56,5	-	400/3/50	1000	253	120x70x100
44011.2	LS 1000 ST												259	120x70x100

serie/series:

INDUSTRIAL SILENT LS - 15 BAR

COMPRESSORI INDUSTRIALI SILENZIATI - BISTADIO - TRASMISSIONE A CINGHIA - LUBRIFICATI
SILENT DOUBLE-STAGE INDUSTRIAL COMPRESSORS WITH BELT DRIVE - OIL LUBRICATED

**QUALITY
MADE IN ITALY**



LS 1000 - 500 - 15 B

Max 68 dB(A)

Codice	Modello	Pressione		N. Cilindri	Potenza Nominale Motore		Aria Aspirata			Serb.	Voltaggio	Giri/min	Peso	Dimensione Imballo
Cod.	Model	Pressure		N. Cylinders	Nominal Motor Rating		Air Displacement			Tank	Voltage	r.p.m.	Weight	Packaging Dimension
-	Series	bar	p.s.i.	Cil.	Hp	kW	lt./min.	CFM	m3/h	lt.	Volt/ph/hz	r.p.m.	kg.	cm
COMPRESSORI SILENZIATI CON SERBATOIO E CON TESTATA - SILENT COMPRESSORS WITH AIR TANK AND COMPRESSOR PUMP														
44107.2	LS 550 - 270	15	218	2	5,5	4	432	15,2	25,9	270 F	400/3/50	1000	248	155x73x165
44207.1	LS 550 - 500									500 F	400/3/50		379	195x73x173
44108.1	LS 750 - 270	15	218	2	7,5	5,5	570	20,1	34,2	270 F	400/3/50	1000	301	155x73x165
44109.1	LS 750 - 270 ST									270 F	400/3/50		307	155x73x165
44208.1	LS 750 - 500	15	218	2	7,5	5,5	570	20,1	34,2	500 F	400/3/50	1000	379	195x73x173
44209.1	LS 750 - 500 ST									500 F	400/3/50		385	195x73x173
44110.1	LS 1000 - 270	15	218	2	10	7,5	942	33,2	56,5	270 F	400/3/50	1000	320	155x73x165
44111.1	LS 1000 - 270 ST									270 F	400/3/50		326	155x73x165
44210.1	LS 1000 - 500	15	218	2	10	7,5	942	33,2	56,5	500 F	400/3/50	1000	417	195x73x173
44211.1	LS 1000 - 500 ST									500 F	400/3/50		423	195x73x173

serie/series:

INDUSTRIAL SILENT LS - 15 BAR

COMPRESSORI INDUSTRIALI SILENZIATI - BISTADIO - TRASMISSIONE A CINGHIA - LUBRIFICATI
SILENT DOUBLE-STAGE INDUSTRIAL COMPRESSORS WITH BELT DRIVE - OIL LUBRICATED

**QUALITY
MADE IN ITALY**



LS 1000 - 500 E - 15 B

Max 68 dB(A)

Codice	Modello	Pressione		N. Cilindri	Potenza Nominale Motore		Aria Aspirata			Serb.	Voltaggio	Giri/min	Peso	Dimensione Imballo
Cod.	Model	Pressure		N. Cylinders	Nominal Motor Rating		Air Displacement			Tank	Voltage	r.p.m.	Weight	Packaging Dimension
-	Series	bar	p.s.i.	Cil.	Hp	kW	lt./min.	CFM	m3/h	lt.	Volt/ph/hz	r.p.m.	kg.	cm
COMPRESSORI SILENZIATI CON SERBATOIO, ESSICCATORE E CON TESTATA - SILENT COMPRESSOR WITH AIR TANK, DRYER AND COMPRESSOR PUMP														
44307.1	LS 550 - 270 E	15	218	2	5,5	4	432	15,2	25,9	270 F	400/3/50	1000	273	155x73x165
44407.1	LS 550 - 500 E									500 F	400/3/50		404	195x73x173
44308.1	LS 750 - 270 E	15	218	2	7,5	5,5	570	20,1	34,2	270 F	400/3/50	1000	326	155x73x165
44309.1	LS 750 - 270 ST E									270 F	400/3/50		332	155x73x165
44408.2	LS 750 - 500 E	15	218	2	7,5	5,5	570	20,1	34,2	500 F	400/3/50	1000	404	195x73x173
44409.1	LS 750 - 500 ST E									500 F	400/3/50		410	195x73x173
44310.1	LS 1000 - 270 E	15	218	2	10	7,5	942	33,2	56,5	270 F	400/3/50	1000	345	155x73x165
44311.1	LS 1000 - 270 ST E									270 F	400/3/50		351	155x73x165
44410.1	LS 1000 - 500 E	15	218	2	10	7,5	942	33,2	56,5	500 F	400/3/50	1000	442	195x73x173
44411.1	LS 1000 - 500 ST E									500 F	400/3/50		448	195x73x173

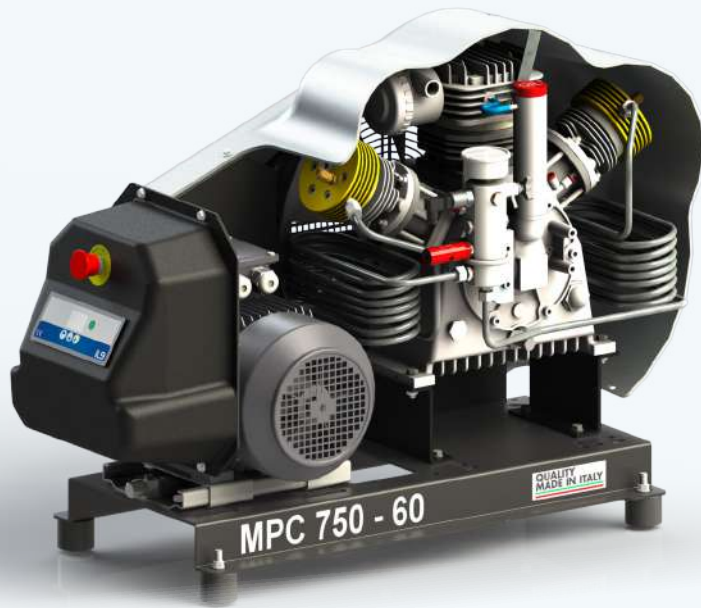

COMPRESSORI A MEDIA PRESSIONE DA 25 A 70 BAR
MEDIUM PRESSURE PISTON COMPRESSORS FROM 25 TO 70 BAR

**QUALITY
MADE IN ITALY**



MPC 750 - 60



MPC 750 - 60

Modello	Aria resa		N. di cilindri/ Stadi	Potenza Motore		Voltaggio	Rumorosità	Peso	Dimensioni
Model	Flow capacity - FAD		Cylinder N./ Stage	Motor Rating		Voltage	Noise Level	Weight	Dimensions
-	lt./min	CFM	-	Hp	kW	Volt/ph/hz	dB(A)	Kg	cm
Versione a / Version at 25.30.40.50.60bar / 363.435.580.725.870psi									
MPC 300M-315	140	4,9	3C / 2S	3	2,2	230/1/50.60	94	93	90x44x54
MPC 400-315	170	5,9		4	3		400/3/50.60	94	93
MPC 550-315	235	8,3		5,5	4	94		100	90x44x54
MPC 750-315	315	11,1		7,5	5,5	95	105	90x44x54	
Versione a / Version at 30.40.50.60.70bar / 435.580.725.870.1015psi									
MPC 750-850	378	13,2	3C / 2S	7,5	5,5	400/3/50.60	95	135	90x44x54
MPC 1000-850	466	16,2		10	7,5		95	140	90x44x54
MPC 1250-850	622	21,9		12,5	9		96	158	90x44x54
MPC 1500-850	850	29,2		15	11		96	176	90x44x54

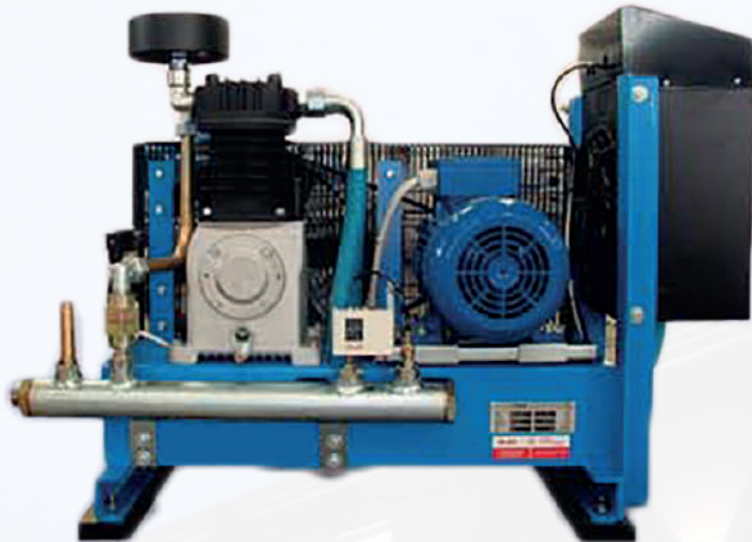
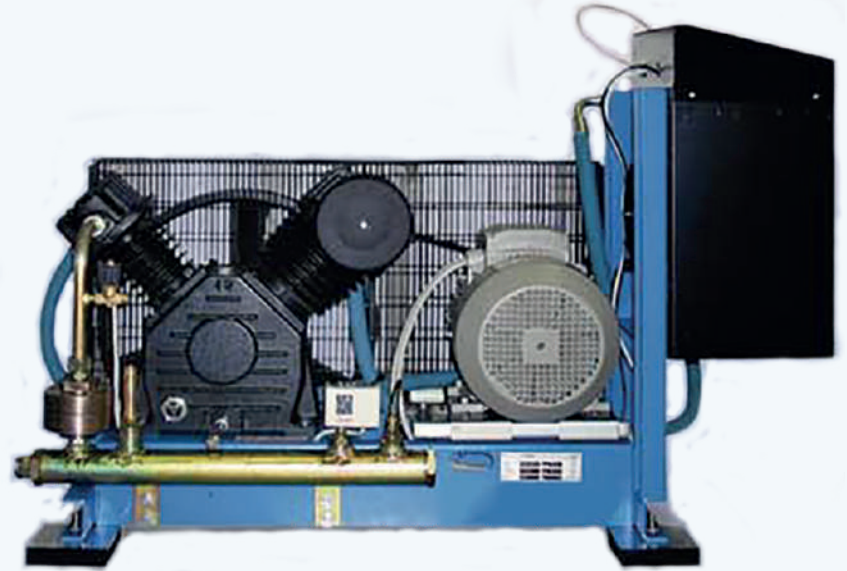

serie/series:



ALTA PRESSIONE
HIGH PRESSURE

QUALITY
MADE IN ITALY

COMPRESSORI A PISTONI ALTA PRESSIONE SU BASAMENTO DA 15 A 40BAR
HIGH PRESSURE PISTON COMPRESSORS ON BASE FROM 15 TO 40BAR

Max 87 dB(A)



PAB 43/85 AP-15

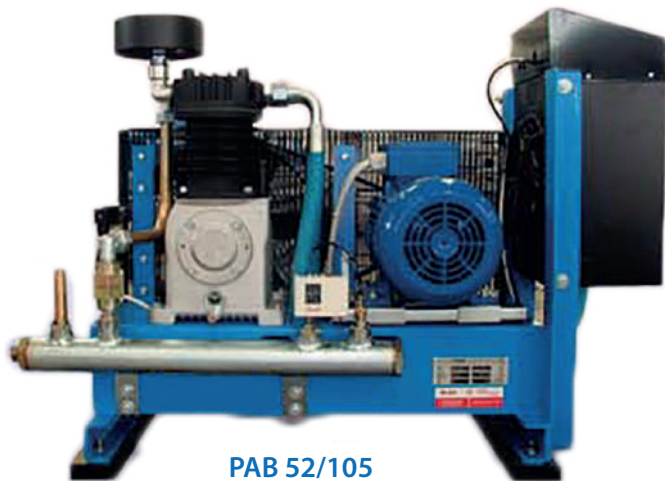

PAB 52/105

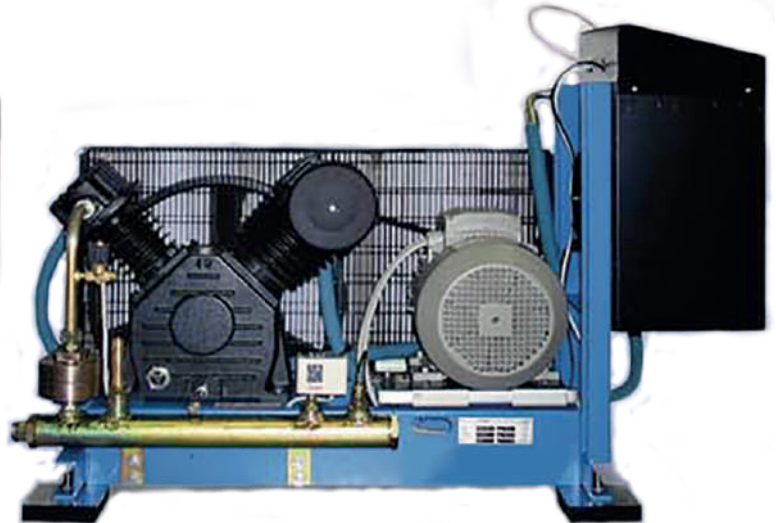

PAB 60/120

PAB SERIES - 15/40 bar

Codice	Modello		Pressione		N. Cilindri	Potenza Nominale Motore		Aria Aspirata			Serb.	Voltaggio	Giri/min	Peso	Dimensione Imballo
Cod.	Model		Pressure		N. Cylinders	Nominal Motor Rating		Air Displacement			Tank	Voltage	r.p.m.	Weight	Packaging Dimension
-	Series	Comp. Pump	bar	p.s.i.	Cil.	Hp	kW	lt./min.	CFM	m3/h	lt.	Volt/ph/hz	r.p.m.	kg.	cm
42001	PAB 43/85	-	15	220	2	4	3	220	7,4	13	-	400/3/50	950	63	105x50x85
42002	PAB 43/85	-	20	292	2	4	3	190	6,4	11,2	-	400/3/50	850	63	105x50x85
42003	PAB 43/85	-	30	438	2	4	3	130	4,4	7,7	-	400/3/50	1050	63	105x50x85
42004	PAB 52/105	-	15	220	2	5,5	4	360	12	21,2	-	400/3/50	830	80	105x50x85
42005	PAB 52/105	-	20	292	2	7,5	5,5	400	13,5	23,5	-	400/3/50	970	82	105x50x85
42006	PAB 52/105	-	30	438	2	7,5	5,5	240	8	14,1	-	400/3/50	720	82	105x50x85
42007	PAB 60/110	-	15	220	2	7,5	5,5	580	19,5	34,2	-	400/3/50	820	210	140x60x85
42008	PAB 60/110	-	20	292	2	10	7,5	640	21,6	37,7	-	400/3/50	990	212	140x60x85
42009	PAB 60/110	-	30	438	2	10	7,5	400	13,5	23,6	-	400/3/50	800	218	140x60x85
42010	PAB 60/110	-	35	511	2	12,5	9	550	17,2	30	-	400/3/50	920	215	140x60x85
42011	PAB 60/120	-	15	220	2	10	7,5	880	29,6	52	-	400/3/50	920	215	140x60x85
42012	PAB 60/120	-	20	292	2	12,5	9	880	29,6	52	-	400/3/50	920	215	140x60x85
42013	PAB 60/120	-	30	438	2	12,5	9	750	25,3	44,2	-	400/3/50	760	215	140x60x85
42013.1	PAB 60/110	-	40	584	2	12,5	9	700	23,6	41,6	-	400/3/50	860	240	140x60x85



serie/series:



ALTA PRESSIONE
HIGH PRESSURE

QUALITY
MADE IN ITALY

COMPRESSORI A PISTONI ALTA PRESSIONE SU SERBATOIO DA 16 A 21BAR
HIGH PRESSURE PISTON COMPRESSORS ON TANK FROM 15 TO 40BAR

Max 86 dB(A)



PAS 2-20



PAS 120-21

PAS SERIES - 15/20 bar

Codice	Modello		Pressione		N. Cilindri	Potenza Nominale Motore		Aria Aspirata			Serb.	Voltaggio	Giri/min	Peso	Dimensione Imballo
Cod.	Model		Pressure		N. Cylinders	Nominal Motor Rating		Air Displacement			Tank	Voltage	r.p.m.	Weight	Packaging Dimension
-	Series	Comp. Pump	bar	p.s.i.	Cil.	Hp	kW	lt./min.	CFM	m3/h	lt.	Volt/ph/hz	r.p.m.	kg.	cm
42014	PAS 2	-	20	292	2	2	1,5	90	3,2	5	1,5	400/3/50	1400	33	58x33x55
42015	PAS 50	-	15	220	2	3	2,2	200	7,1	12	50 F	400/3/50	870	65	95x47x75
42016	PAS 120	-	15	220	2	4	3	220	7,8	13	120 F	400/3/50	950	85	120x51x85
42017	PAS 250	-	15	220	2	5,5	4	360	12,7	22	250 F	400/3/50	830	110	140x53x110
42018	PAS 250	-	15	220	2	7,5	5,5	580	20,5	35	250 F	400/3/50	820	180	155x60x120
42019	PAS 500	-	15	220	2	10	7,5	880	31	54	500 F	400/3/50	920	310	197x60x123
42020	PAS 250 ST	-	15	220	2	5,5	4	360	12,7	22	250 F	400/3/50	830	110	140x53x110
42021	PAS 250 ST	-	15	220	2	7,5	5,5	580	20,5	35	250 F	400/3/50	820	180	155x60x120
42022	PAS 500 ST	-	15	220	2	10	7,5	880	31	54	500 F	400/3/50	920	310	197x60x123
42023	PAS 120	-	20	292	2	4	3	190	6,7	12	120 F	400/3/50	850	85	110x51x85
42024	PAS 250	-	20	292	2	7,5	5,5	400	14,1	24	250 F	400/3/50	970	120	140x53x110
42025	PAS 250	-	20	292	2	10	7,5	640	22,6	39	250 F	400/3/50	970	190	155x60x120
42026	PAS 475	-	20	292	2	12,5	9	880	31	54	475 F	400/3/50	920	320	197x60x123
42027	PAS 250	-	20	292	2	7,5	5,5	400	14,1	24	250 F	400/3/50	970	120	140x53x110
42028	PAS 250	-	20	292	2	10	7,5	640	22,6	39	250 F	400/3/50	990	190	155x60x120
42029	PAS 475	-	20	292	2	12,5	9	880	31	54	475 F	400/3/50	920	320	197x60x123



POWERED by
HONDATM

serie/series:

MOTO KOMP

**QUALITY
MADE IN ITALY**

COMPRESSORI CON MOTORE A SCOPPIO A DIESEL A BENZINA
PETROL AND DIESEL ENGINE COMPRESSORS

Max 94 dB(A)



CRS 1040/260 PL



TTS 2255

TWIN TANK PETROL ENGINE COMPRESSORS - TTS SERIES

Codice	Modello	Pressione	N. Cilindri	Potenza Nominale Motore	Aria Aspirata	Serb.	Voltaggio	Giri/min	Peso	Dimensione Imballo					
Cod.	Model	Pressure	N. Cylinders	Nominal Motor Rating	Air Displacement	Tank	Voltage	r.p.m.	Weight	Packaging Dimension					
-	Series	Comp. Pump	bar	p.s.i.	Cil.	CV	Brand	lt./min.	CFM	m3/h	lt.	Volt/ph/hz	r.p.m.	kg.	cm
MOTOCOMPRESSORE A BENZINA - PETROL ENGINE COMPRESSORS															
42066	CRS 1040	K 11	11	160	2	4	Loncin	260	8,88	15,6	10 C	-	1150	52	69x88x88
42067	CRS 1055	K 17	11	160	2	5,5	Loncin	430	14,7	25,8	10 C	-	1250	58	69x88x88
42068.1	TTS 2265	K 18	11	160	2	6,5	Loncin	520	18,4	31,2	11+11 C	-	1300	68	69x88x88
MOTOCOMPRESSORE A DIESEL - DIESEL ENGINE COMPRESSORS															
42094	CRD 1042	K 17	11	160	2	4,2	Hailin	450	15,5	27,1	10 C	-	1300	64	69x88x88
42090	TTD 2242	K 18	11	160	2	4,2	Hailin	520	18,4	31,2	11+11 C	-	1300	70	69x88x88
42096	TTD 2242 E	K 18	11	160	2	6	Hailin	520	18,4	31,2	11+11 C	-	1300	70	69x88x88

serie/series:

MOTO KOMP

**QUALITY
MADE IN ITALY**

COMPRESSORI CON MOTORE A SCOPPIO A DIESEL E A BENZINA CON DOPPIO SERBATOIO
PETROL AND DIESEL ENGINE COMPRESSORS WITH TWIN TANK

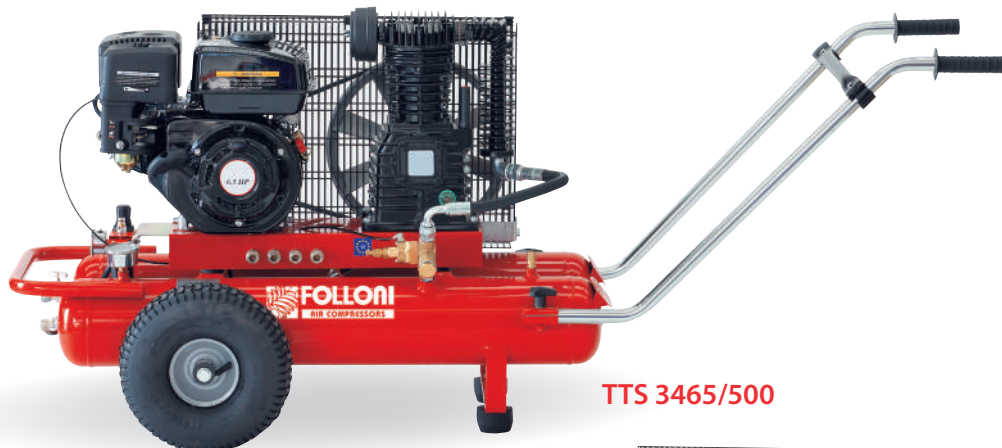

TTS 3465/500

Max 96 dB(A)



TTS 3490/610



TTS 34110/900

TWIN TANK DIESEL ENGINE COMPRESSORS - TTD SERIES

Codice	Modello		Pressione		N. Cilindri	Potenza Nominale Motore		Aria Aspirata			Serb.	Voltaggio	Giri/min	Peso	Dimensione Imballo
Cod.	Model		Pressure		N. Cylinders	Nominal Motor Rating		Air Displacement			Tank	Voltage	r.p.m.	Weight	Packaging Dimension
-	Series	Comp. Pump	bar	p.s.i.	Cil.	CV	Brand	lt./min.	CFM	m3/h	lt.	Volt/ph/hz	r.p.m.	kg.	cm
MOTOCOMPRESSORE A BENZINA - PETROL ENGINE COMPRESSORS															
42069	TTS 3465	K 18	11	160	2	6,5	Loncin	520	18,4	31,2	17+17 C	-	1250	70	69x88x88
42071	TTS 3490	K 28	11	160	2	9	Loncin	610	21,53	36,3	17+17 C	-	1300	118	69x88x88
42074	TTS 34110	K 30	11	160	2	11	Loncin	900	31,77	54,1	17+17 C	-	1250	140	69x88x88
MOTOCOMPRESSORE A DIESEL - DIESEL ENGINE COMPRESSORS															
42091	TTD 3460	K 28	11	160	2	6	Hailin	610	21,5	36,6	17+17 C	-	1300	160	69x88x88
42092	TTD 3496	K 30	11	160	2	9,6	Hailin	900	37,8	54,1	17+17 C	-	1300	165	69x88x88

serie/series:

MOTO KOMP

**QUALITY
MADE IN ITALY**

COMPRESSORI CON MOTORE A SCOPPIO A DIESEL E A BENZINA
PETROL AND DIESEL ENGINE COMPRESSORS

Max 96 dB(A)

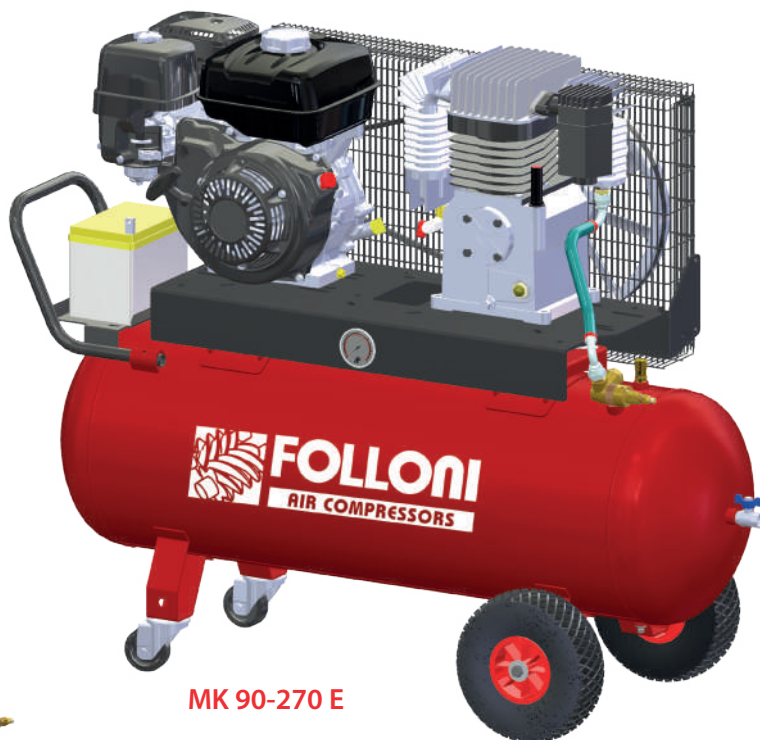
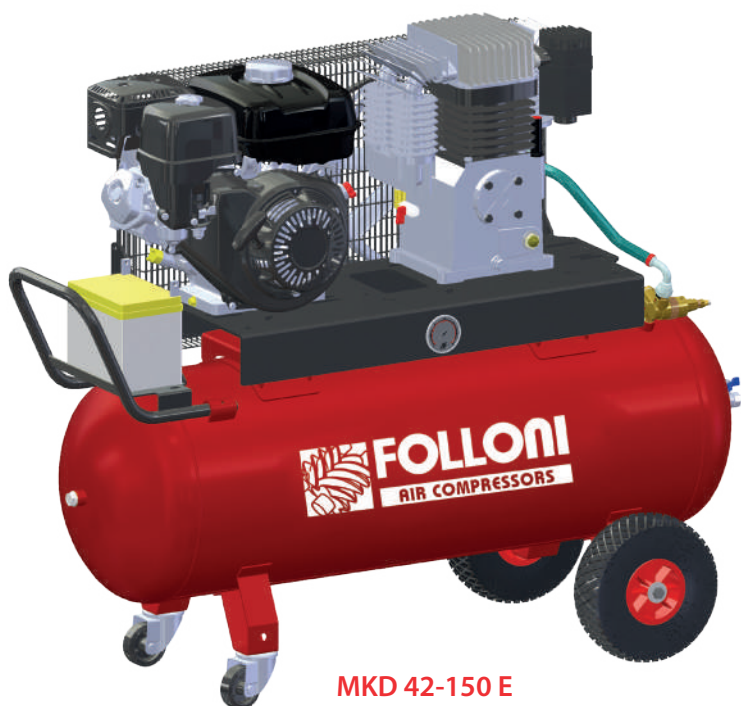

PETROL ENGINE COMPRESSORS - MK SERIES - 5,5/6,5 CV

Codice	Modello		Pressione		N. Cilindri	Potenza Nominale Motore		Aria Aspirata			Serb.	Voltaggio	Giri/min	Peso	Dimensione Imballo
Cod.	Model		Pressure		N. Cylinders	Nominal Motor Rating		Air Displacement			Tank	Voltage	r.p.m.	Weight	Packaging Dimension
-	Series	Comp. Pump	bar	p.s.i.	Cil.	CV	Brand	lt./min.	CFM	m3/h	lt.	Volt/ph/hz	r.p.m.	kg.	cm
MOTOCOMPRESSORE A BENZINA - PETROL ENGINE COMPRESSORS															
42210	MK 55 - 100	K 11									100 C			95	49x127x88
42211	MK 55 - 150	K 11	10	145	2	5,5	Loncin	220	8	13	150 C	-	1200	104	51x149x92
42212	MK 55 - 200	K 11									200 C			120	53x158x101
42220	MK 55P - 100	K 17									100 C			95	49x127x88
42221	MK 55P - 150	K 17	10	145	2	5,5	Loncin	321	11	19	150 C	-	1200	104	51x149x92
42222	MK 55P - 200	K 17									200 C			120	53x158x101
42230	MK 65 - 100	K 18									100 C			95	49x127x88
42231	MK 65 - 150	K 18	10	145	2	6,5	Loncin	385	14	23	150 C	-	1200	104	51x149x92
42232	MK 65 - 200	K 18									200 C			120	53x158x101
MOTOCOMPRESSORE A DIESEL - DIESEL ENGINE COMPRESSORS															
42310	MKD 42 - 100 E	K 18									100 C			104	49x127x88
42311	MKD 42 - 150 E	K 18	10	145	2	4,2	Hailin	520	18	31	150 C	-	1200	120	51x149x92
42312	MKD 42 - 200 E	K 18									200 C			154	53x158x101

serie/series:

MOTO KOMP

**QUALITY
MADE IN ITALY**

COMPRESSORI CON MOTORE A SCOPPIO A DIESEL E A BENZINA
PETROL AND DIESEL ENGINE COMPRESSORS

Max 96 dB(A)

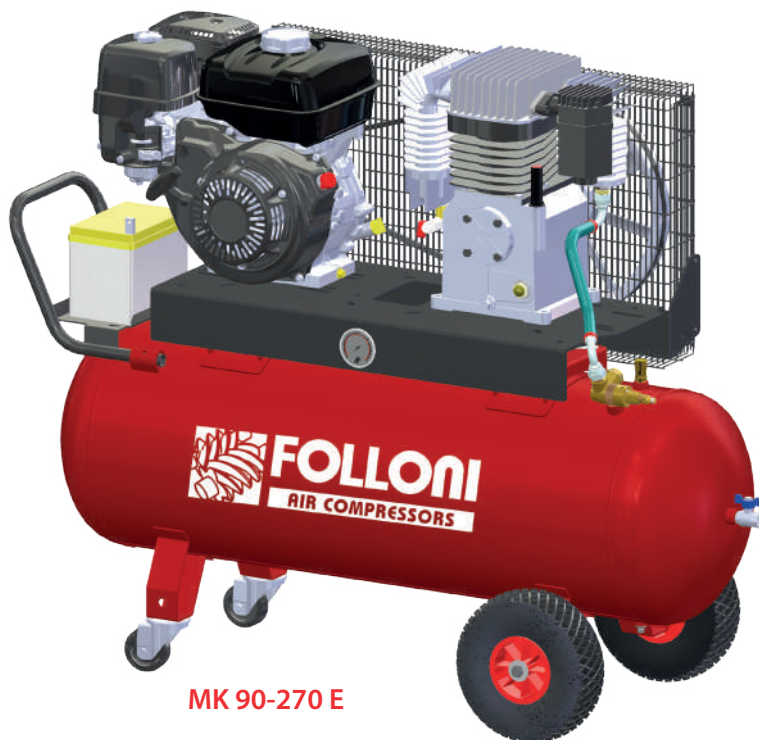
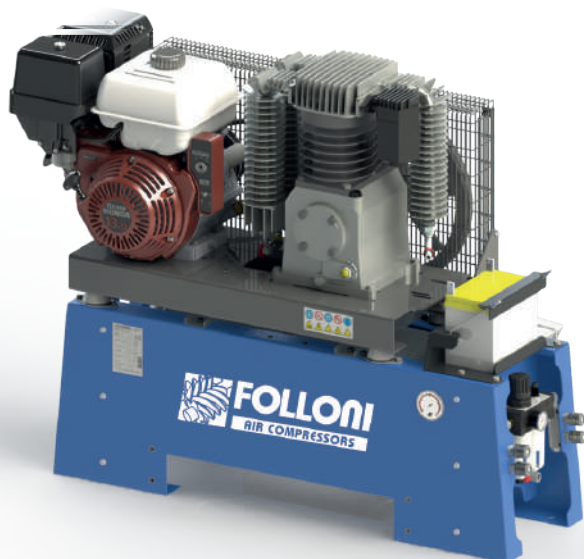

MK 90-270 E

PETROL ENGINE COMPRESSORS - MK SERIES - 9 CV

Codice	Modello		Pressione		N. Cilindri	Potenza Nominale Motore		Aria Aspirata			Serb.	Voltaggio	Giri/min	Peso	Dimensione Imballo
Cod.	Model		Pressure		N. Cylinders	Nominal Motor Rating		Air Displacement			Tank	Voltage	r.p.m.	Weight	Packaging Dimension
-	Series	Comp. Pump	bar	p.s.i.	Cil.	CV	Brand	lt./min.	CFM	m3/h	lt.	Volt/ph/hz	r.p.m.	kg.	cm
MOTOCOMPRESSORE A BENZINA - PETROL ENGINE COMPRESSORS															
42240	MK 90 - 100 E	K 28	10	145	2	9	Loncin	610	22	37	100 C	-	1200	95	49x127x88
42242	MK 90 - 200 E	K 28	10	145	2	9	Loncin	610	22	37	200 C	-	1200	120	53x158x101
42243	MK 90 - 270 E	K 28	10	145	2	9	Loncin	610	22	37	270 C	-	1200	153	72x170x115
42244	MK 90 - 500 E	K 28	10	145	2	9	Loncin	610	22	37	500 C	-	1200	180	74x213x135
42249	MK 110 - 50 E	K 30	10	145	2	11	Loncin	900	32	54	50 F	-	1200	95	140x55x100
42252	MK 110 - 200 E	K 30	10	145	2	11	Loncin	900	32	54	200 C	-	1200	120	53x158x101
42253	MK 110 - 270 E	K 30	10	145	2	11	Loncin	900	32	54	270 C	-	1200	153	72x170x115
42254	MK 110 - 500 E	K 30	10	145	2	11	Loncin	900	32	54	500 C	-	1200	180	74x213x135
MOTOCOMPRESSORE A DIESEL - DIESEL ENGINE COMPRESSORS															
42320	MKD 60 - 100 E	K 28	10	145	2	5,5	Hailin	610	22	37	100 C	-	1200	104	49x127x88
42322	MKD 60 - 200 E	K 28	10	145	2	5,5	Hailin	610	22	37	200 C	-	1200	154	53x158x101
42329	MKD 96 - 50 E	K 30	10	145	2	9,6	Hailin	900	32	54	50 F	-	1200	95	140x55x100
42332	MKD 96 - 200 E	K 30	10	145	2	9,6	Hailin	900	32	54	200 C	-	1200	120	53x158x101
42333	MKD 96 - 270 E	K 30	10	145	2	9,6	Hailin	900	32	54	270 C	-	1200	153	72x170x115
42334	MKD 96 - 500 E	K 30	10	145	2	9,6	Hailin	900	32	54	500 C	-	1200	180	74x213x135

serie/series:

MOTO KOMP

**QUALITY
MADE IN ITALY**

COMPRESSORI CON MOTORE A SCOPPIO A DIESEL E A BENZINA
PETROL AND DIESEL ENGINE COMPRESSORS

POWERED by
HONDA™

Max 96 dB(A)



MK 90-270

PETROL ENGINE COMPRESSORS - MK ECO SERIES

Codice	Modello		Pressione		N. Cilindri	Potenza Nominale Motore		Aria Aspirata			Serb.	Voltaggio	Giri/min	Peso	Dimensione Imballo
Cod.	Model		Pressure		N. Cylinders	Nominal Motor Rating		Air Displacement			Tank	Voltage	r.p.m.	Weight	Packaging Dimension
-	Series	Comp. Pump	bar	p.s.i.	Cil.	CV	Brand	lt./min.	CFM	m3/h	lt.	Volt/ph/hz	r.p.m.	kg.	cm
42210.1.H	MK ECO 55 - 100	NG 3	10	145	2	5,5	Honda	220	8	13	100 C	-	1200	95	49x127x88
42210.1.L	MK ECO 55 - 100						Loncin	220			100 C	-			
42212.1.H	MK ECO 55 - 200	NG 3	10	145	2	5,5	Honda	220	8	13	200 C	-	1200	120	53x158x101
42212.1.L	MK ECO 55 - 200						Loncin	220			200 C	-			
42233.1.H	MK ECO 65 - 270	NG 4	10	145	2	6,5	Honda	385	14	23	270 C	-	1200	140	72x170x115
42233.1.L	MK ECO 65 - 270						Loncin	385			270 C	-			
42243.1.H	MK ECO 90 - 270	NG 5	10	145	2	9	Honda	610	22	37	270 C	-	1200	153	72x170x115
42243.1.L	MK ECO 90 - 270						Loncin	610			270 C	-			
42253.1.H	MK ECO 110 - 270	NG 6	10	145	2	11	Honda	900	32	54	270 C	-	1200	153	72x170x115
42253.1.L	MK ECO 110 - 270						Loncin	900			270 C	-			
42254.1.H	MK ECO 110 - 500	NG 6	10	145	2	11	Honda	900	32	54	500 C	-	1200	180	74x213x135
42254.1.L	MK ECO 110 - 500						Loncin	900			500 C	-			

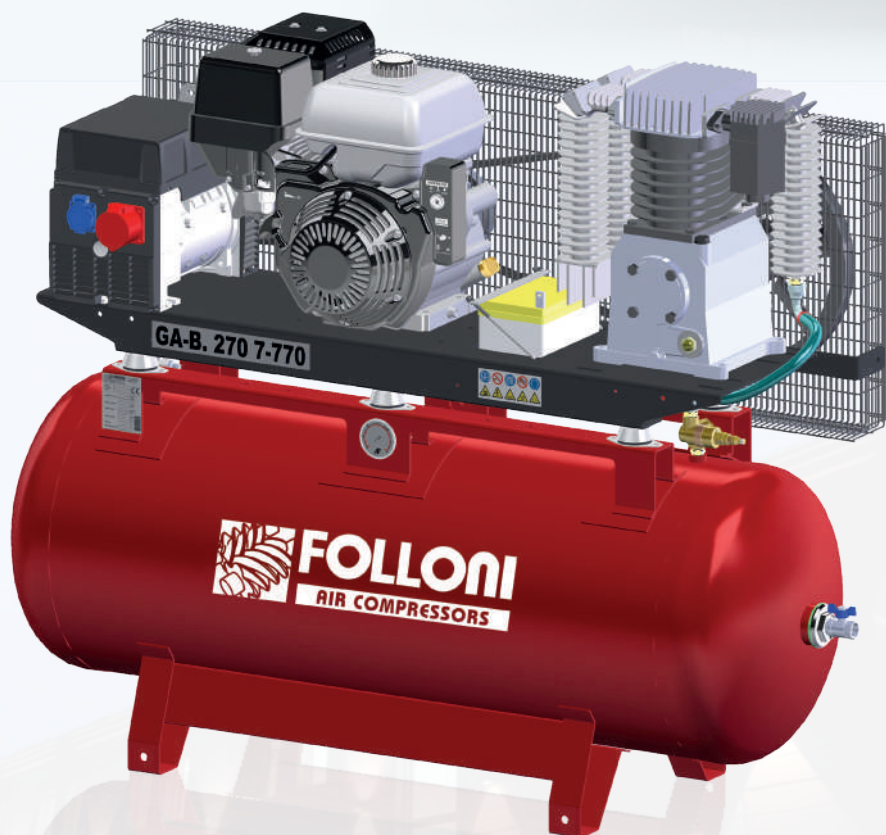
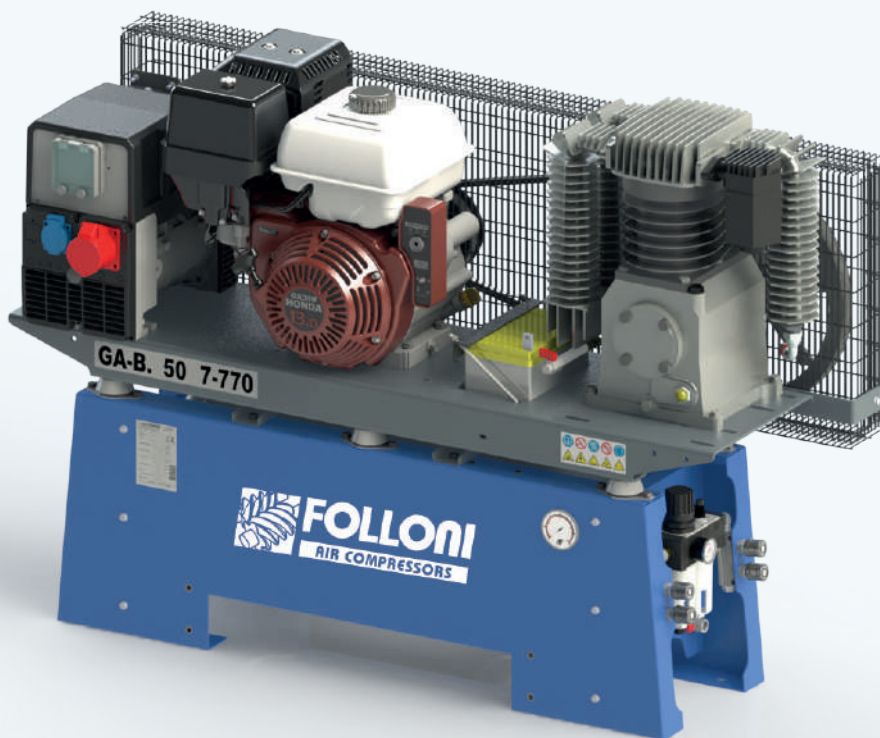

POWERED by
HONDATM

serie/series:



**QUALITY
MADE IN ITALY**

COMPRESSORI CON MOTORE A SCOPPIO A DIESEL E A BENZINA CON GENERATORE
PETROL AND DIESEL ENGINE COMPRESSORS WITH GENERATOR

**POWERED by
HONDA™**

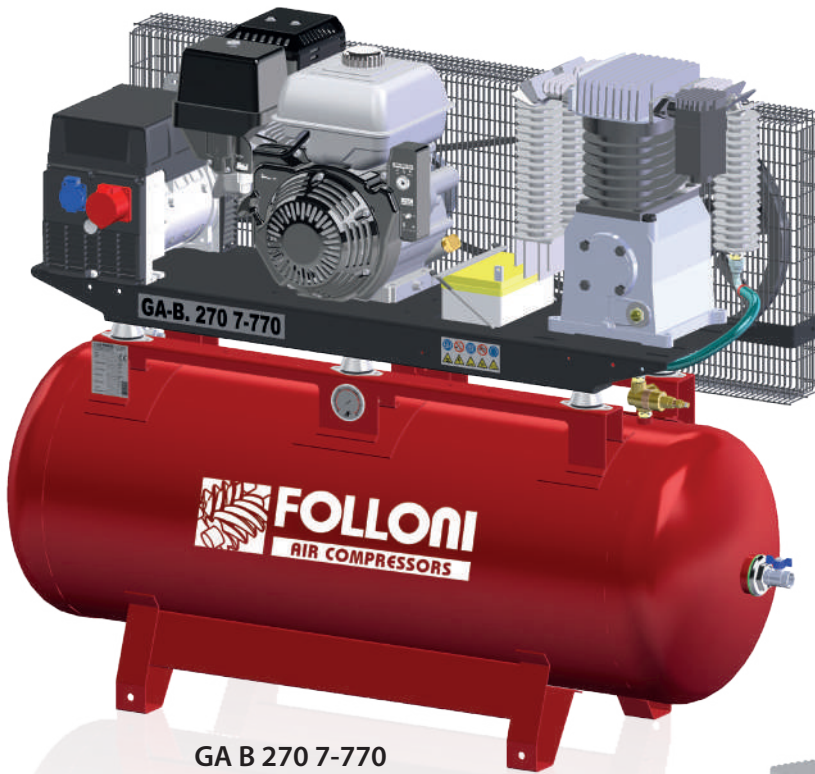

GA B 270 7-770

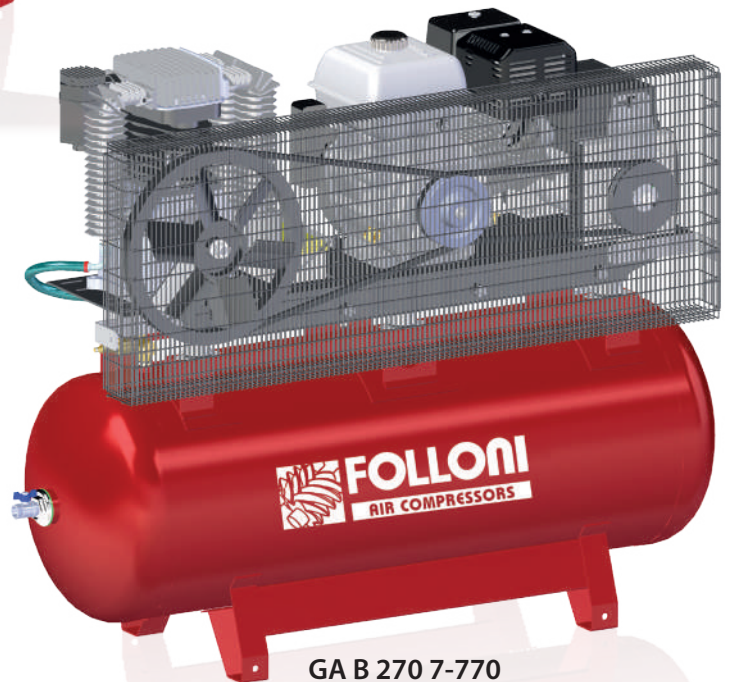

GA B 270 7-770

Max 96 dB(A)

ENGINE COMPRESSOR WITH GENERATOR - GENAIR GA SERIES

Codice	Modello		Pressione		N. Cilindri	Potenza Generatore		Potenza Nominale Motore		Aria Aspirata			Serb.	Voltaggio	Giri/min	Peso	Dimensione Imballo
Cod.	Model		Pressure		N. Cylinders	Generator Rating		Nominal Motor Rating		Air Displacement			Tank	Voltage	r.p.m.	Weight	Packaging Dimension
-	Series	Comp. Pump	bar	p.s.i.	Cil.	Kva	kW	Cv	Brand	lt./min.	CFM	m3/h	lt.	Volt/ph/hz	r.p.m.	kg.	cm
MOTOCOMPRESSORE CON GENERATORE A BENZINA - PETROL ENGINE COMPRESSORS WITH GENERATOR																	
45100	GA - B 270 7-770	K 30	10	145	2	7	5,6	11	Loncin	700	24,6	43,7	270	230-400/50	1200	215	178x72x115
45100.H	GA - B 270 7-770 H	K 30	10	145	2	7	5,6	11	Honda	700	24,6	43,7	270	230-400/50	1200	215	178x72x115
MOTOCOMPRESSORE CON GENERATORE A DIESEL - DIESEL ENGINE COMPRESSORS WITH GENERATOR																	
45200	GA - D 270 7-770	K 30	10	145	2	7	5,6	9,6	Hailin	700	24,6	43,7	270	230-400/50	1200	215	178x72x115

serie/series:



**QUALITY
MADE IN ITALY**

COMPRESSORI CON MOTORE A SCOPPIO A DIESEL E A BENZINA CON GENERATORE
PETROL AND DIESEL ENGINE COMPRESSORS WITH GENERATOR

**POWERED by
HONDA™**

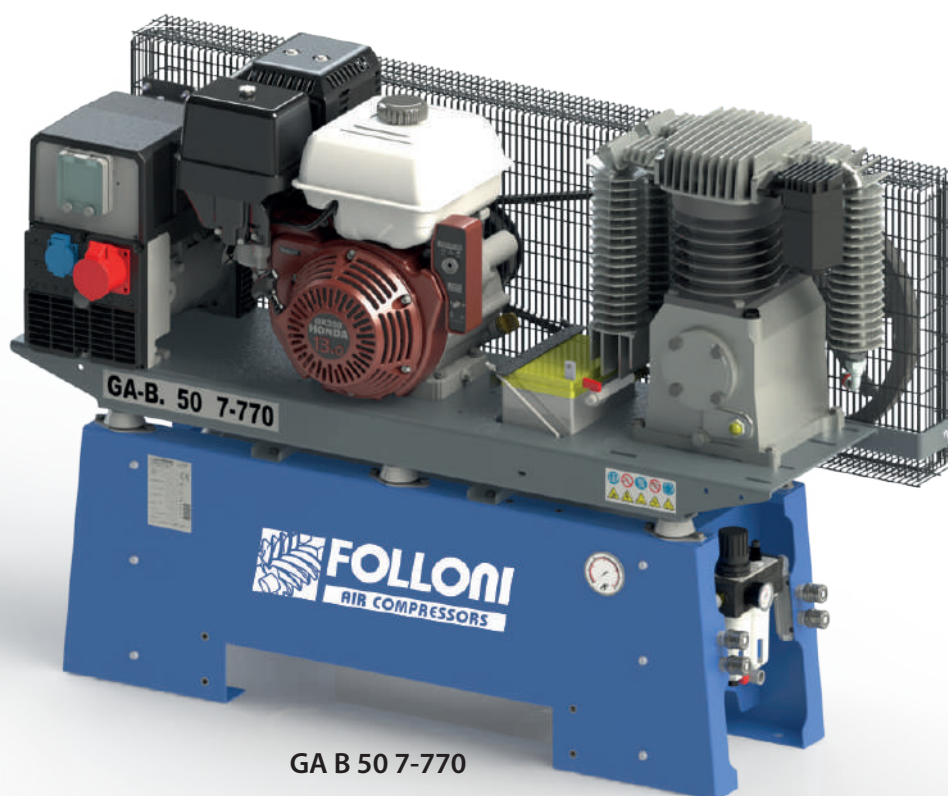

GA B 50 7-770

Max 96 dB(A)

ENGINE COMPRESSOR WITH GENERATOR - GENAIR GA SERIES

Codice	Modello	Pressione	N. Cilindri	Potenza Generator	Potenza Nominale Motore	Aria Aspirata	Serb.	Voltaggio	Giri/min	Peso	Dimensione Imballo	
Cod.	Model	Pressure	N. Cylinders	Generator Rating	Nominal Motor Rating	Air Displacement	Tank	Voltage	r.p.m.	Weight	Packaging Dimension	
-	Series	Comp. Pump bar p.s.i.	Cil.	Kva kW	Cv Brand	lt./min. CFM m3/h	lt.	Volt/ph/hz	r.p.m.	kg.	cm	
MOTOCOMPRESSORE CON GENERATORE A BENZINA - PETROL ENGINE COMPRESSORS WITH GENERATOR												
45300	GA - B 50 7-770	K 30	10 145	2	7 5,6	11	Loncin	700 24,6 43,7	50	230-400/50	1200	215 139x52x98
45300.H	GA - B 50 7-770 H	K 30	10 145	2	7 5,6	11	Honda	700 24,6 43,7	50	230-400/50	1200	215 139x52x98
MOTOCOMPRESSORE CON GENERATORE A DIESEL - DIESEL ENGINE COMPRESSORS WITH GENERATOR												
45400	GA - D 50 7-770	K 30	10 145	2	7 5,6	9,6	Hailin	700 24,6 43,7	50	230-400/50	1200	215 139x52x98



serie/series:

PROAIR

SUPER SILENT

COMPRESSORI A PISTONI ALTA PROFESSIONALITÀ MONOSTADIO - TRASMISSIONE DIRETTA COASSIALE
HIGH PERFORMANCE PISTON COMPRESSORS - COAXIAL DIRECT DRIVE

**QUALITY
MADE IN ITALY**



PSS 50/9

Max 40 dB(A)



PSS 100/50

SUPER SILENT PISTON COMPRESSORS - PSS SERIES

Codice	Modello		Pressione		N. Cilindri	Potenza Nominale Motore		Aria Aspirata			Serb.	Voltaggio	Giri/min	Peso	Dimensione Imballo
Cod.	Model		Pressure		N. Cylinders	Nominal Motor Rating		Air Displacement			Tank	Voltage	r.p.m.	Weight	Packaging Dimension
-	Series	-	bar	p.s.i.	Cil.	Hp	kW	lt./min.	CFM	m3/h	lt.	Volt/ph/hz	r.p.m.	kg.	cm
89501	PSS 50/9		8	116	1	0,5	0,37	32	1,1	1,92	9	230/1/50-60	1400	21	34x34x50
89502	PSS50/24		8	116	1	0,5	0,37	32	1,1	1,92	24	230/1/50-60	1400	24	42x42x64
89503	PSS100/50		8	116	1	1	0,75	64	2,2	3,84	50	230/1/50-60	1400	45	90x50x80

COMPRESSORS PUMPS

**QUALITY
MADE IN ITALY**



serie/series:

COMPRESSORS PUMPS

GRUPPI COMPRESSORI MONOSTADIO
SINGLE-STAGE COMPRESSOR PUMPS

**QUALITY
MADE IN ITALY**



PXD 200



PNG 4

Codice	Modello		Pressione		N. Cilindri	Potenza Nominale Motore		Aria Aspirata			Giri Mot.	Voltaggio	Peso	Volano
Cod.	Model		Pressure		N. Cylinders	Nominal Motor Rating		Air Displacement			Rev. Mot.	Voltage	Weight	Beltwheel
-	Comp. Pump	Trasmis.	bar	p.s.i.	Cil.	Hp	kW	lt./min.	CFM	m3/h	r.p.m	Volt/ph/hz	kg.	mm-inch-Type
GRUPPI COMPRESSORI MONOSTADIO - SINGLE STAGE COMPRESSORS PUMPS														
12000	PXD 200	Direct	8	116	1	2	1,5	233	8,2	14	2850	-	12,6	-
12009	PN2,8	Belt	10	131	1	2	1,5	253	8,9	15,2	1400	-	6	273-10,8-1A
12010	PNG2,8	Belt	10	131	1	2	1,5	253	8,9	15,2	1400	-	6	273-10,8-1A
12201	K11	Belt	10	131	2	2	1,5	260	9,2	15,6	1000	-	10	280-11,02-1A
12042	PXDV 300	Direct	10	145	1	3	2,2	360	12,7	21,6	2850	-	33	-
12014	PN3	Belt	10	131	1	3	2,2	315	11,1	18,9	1400	-	9	273-10,8-1A
12015	PNG3	Belt	10	131	1	3	2,2	315	11,1	18,9	1400	-	13	273-10,8-1A
12202	K17	Belt	10	131	2	3	2,2	465	16,4	27,9	1000	-	15	320-12,6-1A
12016	PN4	Belt	10	131	1	4	3	541	19,1	32,5	1400	-	12	363-14,3-1A
12017	PNG4	Belt	10	131	1	4	3	541	19,1	32,5	1400	-	15	363-14,3-1A
12203	K18	Belt	10	131	2	4	3	539	19	32,4	1100	-	17	320-12,6-1A

serie/series:

COMPRESSORS PUMPS

GRUPPI COMPRESSORI BISTADIO
DOUBLE-STAGE COMPRESSOR PUMPS

**QUALITY
MADE IN ITALY**



PNG 5



K 30

Codice	Modello		Pressione		N. Cilindri	Potenza Nominale Motore		Aria Aspirata			Giri Mot.	Voltaggio	Peso	Volano
Cod.	Model		Pressure		N. Cylinders	Nominal Motor Rating		Air Displacement			Rev. Mot.	Voltage	Weight	Beltwheel
-	Comp. Pump	Trasmis.	bar	p.s.i.	Cil.	Hp	kW	lt./min.	CFM	m3/h	r.p.m	Volt/ph/hz	kg.	mm-inch-Type
GRUPPI COMPRESSORI MONOSTADIO - SINGLE STAGE COMPRESSORS PUMPS														
12018	P 43/85	Belt	12	175	2	4	3	380	13,4	22,8	1100	-	18	300-11,8-1A
12019	P 52/105	Belt	12	175	2	5,5	4	606	21,4	36,4	900	-	32	350-13,8-1A
12022	PN5	Belt	11	159	2	5,5	4	606	21,4	36,4	1400	-	22	423-16,7-2A
12023	PNG5	Belt	11	159	2	5,5	4	606	21,4	36,4	1400	-	29	423-16,7-2A
12204	K 28	Belt	11	159	2	5,5	4	662	23,4	39,7	1290	-	26	385-15,16-1A
12024	PN6	Belt	11	159	2	7,5	5,5	798	28,2	47,9	1400	-	27	423-16,7-2A
12025	PNG6	Belt	11	159	2	7,5	5,5	798	28,2	47,9	1400	-	29	423-16,7-2A
12205	K 30	Belt	11	159	2	7,5	5,5	872	31	52,3	1150	-	38	400-15,75-1B
12026	PNV 10	Belt	11	159	4	10	7,5	1246	44,1	74,8	1150	-	37	423-16,7-2A
12027	PNGV 10	Belt	11	159	4	10	7,5	1246	44,4	74,8	1150	-	47	423-16,7-2A
12212	K 50	Belt	11	159	2	10	7,5	1240	43,8	74,4	1150	-	71	550-21,65-2B
12028	PNGV15	Belt	11	159	4	15	11	1505	53,2	90,3	1150	-	50	423-16,7-2A

serie/series:

COMPRESSORS PUMPS

GRUPPI COMPRESSORI BISTADIO ALTA PRESSIONE
HIGH PRESSURE DOUBLE-STAGE COMPRESSOR PUMPS

**QUALITY
MADE IN ITALY**



PNGV10-15b / PNGV15-15b



P52/105AP-16

Codice	Modello		Pressione		N. Cilindri	Potenza Nominale Motore		Aria Aspirata			Giri Mot.	Voltaggio	Peso	Volano
Cod.	Model		Pressure		N. Cilinders	Nominal Motor Rating		Air Displacement			Rev. Mot.	Voltage	Weight	Beltwheel
-	Comp. Pump	Trasmis.	bar	p.s.i.	Cil.	Hp	kW	lt./min.	CFM	m3/h	r.p.m	Volt/ph/hz	kg.	mm-inch-Type
GRUPPI COMPRESSORI ALTA PRESSIONE - HIGH PRESSURE COMPRESSORS PUMPS														
12023.1	PNG 5 - 15b	Belt	15	218	2	5,5	4	432	15,3	25,9	1000	-	26,2	423-16,7-2A
12025.1	PNG6-15b	Belt	15	218	2	7,5	5,5	570	20,1	34,2	1000	-	29	423-16,7-2A
12027.1	PNGV 10- 15b	Belt	15	218	4	10	7,5	942	33,3	56,5	1000	-	43,6	423-16,7-2A
12028.1	PNGV 15- 15b	Belt	15	218	4	15	11	1140	40,3	68,4	1000	-	46,2	423-16,7-2A
12029	P43/85AP 16	Belt	16	233	2	3	2,2	220	7,8	13,2	950	-	18	290-11,4-1A
12030	P43/85AP 20	Belt	20	292	2	4	3	190	6,7	11,4	850	-	18	290-11,4-1A
12031	P43/85AP 30	Belt	30	437	2	4	3	130	4,6	7,8	1050	-	18	290-11,4-1A
12032	P52/105AP 16	Belt	16	233	2	5,5	4	360	12,7	21,6	830	-	33	385-15,2-2A
12033	P52/105AP 20	Belt	20	292	2	7,5	5,5	400	14,1	24	970	-	33	385-15,2-2A
12034	P52/105AP 30	Belt	30	437	2	7,5	5,5	240	8,5	14,4	720	-	33	385-15,2-2A
12035	P60/110AP 16	Belt	16	233	2	7,5	5,5	580	20,5	34,8	820	-	63	385-15,2-2A
12036	P60/110AP 20	Belt	20	292	2	10	7,5	640	22,6	38,4	990	-	63	385-15,2-2A
12037	P60/110AP 30	Belt	30	437	2	10	7,5	400	14,2	24	800	-	63	500-19,7-2B
12039	P60/120AP 16	Belt	16	233	2	10	7,5	880	19,5	52,8	850	-	63	500-19,7-2B
12038	P60/110AP 35	Belt	35	510	2	12,5	9	550	31,2	33	920	-	100	500-19,7-2B
12040	P60/120AP 20	Belt	20	292	2	12,5	9	880	31,2	52,8	920	-	100	500-19,7-2B
12041	P60/120AP 30	Belt	30	437	2	12,5	9	775	27,4	46,5	760	-	100	500-19,7-2B

serie/series:

COMPRESSORS PUMPS

GRUPPI COMPRESSORI BISTADIO OILFREE
OILFREE DOUBLE-STAGE COMPRESSOR PUMPS

**QUALITY
MADE IN ITALY**

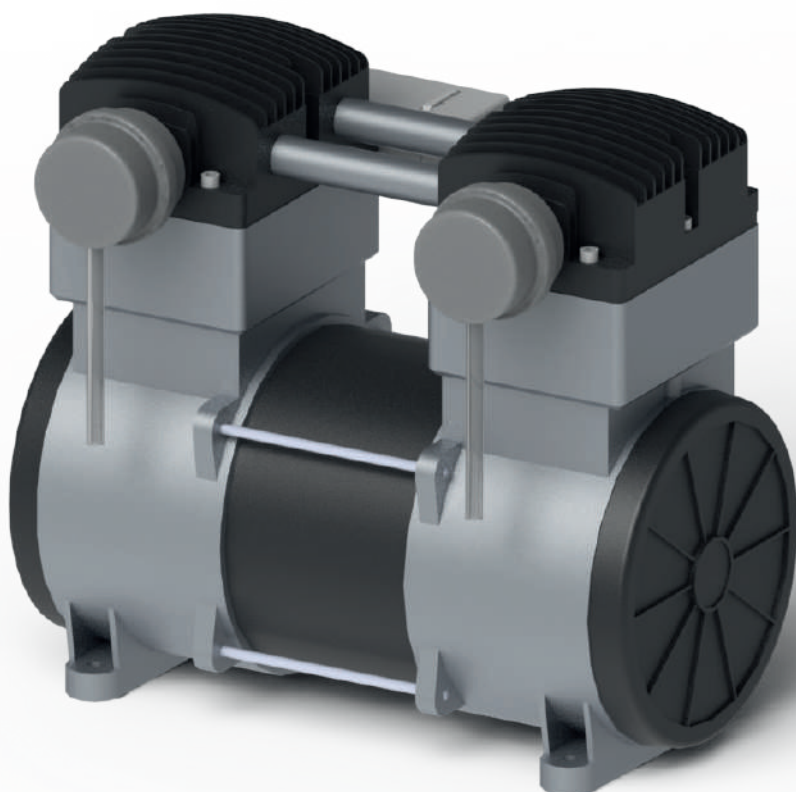

Codice	Modello		Pressione		N. Cilindri	Potenza Nominale Motore		Aria Aspirata			Giri Mot.	Voltaggio	Peso	Volano
Cod.	Model		Pressure		N. Cylinders	Nominal Motor Rating		Air Displacement			Rev. Mot.	Voltage	Weight	Beltwheel
-	Comp. Pump	Trasmis.	bar	p.s.i.	Cil.	Hp	kW	lt./min.	CFM	m3/h	r.p.m	Volt/ph/hz	kg.	mm-inch-Type
GRUPPI COMPRESSORI SENZA OLIO - OIL-FREE COMPRESSORS PUMPS														
12120	C 90	-	8	116	2	1	0,75	95	3,4	5,7	1400	230/1/50-60	9	-
12121	C 196	-	8	116	2	1,5	1	190	6,7	11,4	1400	230/1/50-60	17	-
12122	C 200	-	8	116	2	2	1,5	220	7,7	13,2	1400	230/1/50-60	20	-

CONDIZIONI GENERALI DI VENDITA

GENERAL CONDITIONS OF SALE - CONDITIONS GÉNÉRALES DE VENTE - ALLGEMEINE VERKAUFSBEDINGUNGEN - CONDICIONES GENERALES DE VENTA

La merce indicata s'intende venduta alle condizioni generali di vendita indicate nella copia commissione, nella conferma d'ordine e riportate qui di seguito.

- 1) Salvo diversa pattuizione tutte le consegne sono effettuate franco stabilimento. Tale trasferimento di rischio esclude la sospensione o il ritardo nei pagamenti motivato da danni verificatisi durante il trasporto. Qualora la venditrice giudichi necessario l'imballaggio questo verrà fatturato al costo.
 - 1.1) La merce viaggia a rischio e pericolo del compratore anche se resa franco di porto.
- 2) L'ordine è considerato impegnativo per la venditrice solo dopo la conferma scritta di quest'ultima, mentre per il compratore lo è dal momento dell'ordine.
- 3) Prezzi, misure, pesi e tutti i dati tecnici presenti su listini, cataloghi, circolari o altro materiale pubblicitario (a meno che contrattualmente stabiliti) devono intendersi indicativi causa le fluttuazioni di prezzi dei mercati e le variazioni dovute a necessità di adeguamento tecnico ed estetico.
- 4) I termini di consegna devono intendersi indicativi e in nessun caso potrà essere richiesto alla venditrice il rimborso di eventuali danni per ritardata consegna, né il ritardo può costituire motivo di rescissione dell'ordine.
- 5) PAGAMENTO
 - 5.1) La merce passerà in proprietà del compratore soltanto con il versamento dell'ultima rata, intendendosi venduta con il patto di riservato dominio fino al pagamento dell'intero prezzo. Qualsiasi utilizzo o movimento della stessa merce prima dell'intero pagamento dovrà essere autorizzata dalla venditrice.
 - 5.2) Nel caso di mancato pagamento anche di una sola rata, la venditrice avrà la facoltà di desistere l'immediato pagamento di tutto il residuo prezzo, comprese le rate non scadute (art. 1186 C.C.) inoltre avrà la facoltà di rescindere il contratto e sospendere la fornitura, qualora questa fosse ancora in corso. La venditrice si riserva il diritto di pretendere gli eventuali danni subiti.
 - 5.3) Luogo di pagamento è la sede della venditrice.
- 6) Ogni circostanza sopravvenuta indipendentemente dalla volontà della venditrice e impediante la regolare esecuzione dell'ordine è considerata come giusto motivo di esonero dell'esecuzione stessa. Sono considerate "indipendenti dalla volontà" tutte le circostanze che non risultano da una colpa grave della venditrice. In tale caso la venditrice deve informare per iscritto il compratore all'inizio e alla fine del sussistere della causa. Nel caso in cui l'esecuzione dell'ordine dovesse rendersi impossibile nell'ambito di un ragionevole ritardo, ciascuna delle parti avrà la facoltà di risolvere il contratto mediante una semplice comunicazione scritta.
- 7) Il compratore deve verificare la conformità del materiale al ricevimento dello stesso e, in caso di reclamo, deve immediatamente avvisare la venditrice. Ogni reclamo deve pervenire alla venditrice nei termini di 14 giorni dalla data di spedizione. Oltre tale termine non verranno accettati reclami. Ogni difetto riscontrato dopo il trasferimento del rischio non può essere reclamato.
- 8) Nel caso in cui il compratore non ritiri la merce nei termini stabiliti dall'ordine, per qualsiasi causa non dipendente dalla venditrice, dovrà corrispondere comunque l'importo pattuito per l'intera fornitura, compresa la parte eventualmente ancora da consegnare. Al compratore saranno addebitati i costi di immagazzinaggio, di rischio e finanziari e quant'altro sostenuto per mantenere le merci per la spedizione. Vanno inoltre gli eventuali aumenti del listino nel frattempo intervenuti. Sono fatti salvi gli ulteriori danni che la venditrice dovesse sostenere.
- 9) Nel caso di risoluzione del contratto per volontà del compratore, questi è tenuto all'immediato versamento di una somma pari al 30% della somma pattuita e ciò ai sensi dell'art. 1382 Cod. Civ. senza alcun pregiudizio al diritto per il risarcimento degli eventuali danni subiti dalla medesima venditrice.
- 10) GARANZIA
 - 10.1) Vista la particolarità dei beni venduti la venditrice li garantisce nelle condizioni normali d'uso come da catalogo per un periodo di 24 mesi dalla data di consegna, durante il quale si impegna a sua insindacabile scelta a sostituire o riparare i pezzi riconosciuti difettosi.
 - 10.2) Sono esclusi dalla garanzia:
 - parti elettriche e automatismi di controllo,
 - difetti dovuti a cause di forza maggiore,
 - ogni componente della merce nel caso in cui si rilevi una violazione o una modificazione fatta da personale non autorizzato della venditrice,
 - difetti derivanti da un'installazione imperfetta,
 - difetti derivanti da una insufficiente manutenzione o pulizia,
 - difetti derivanti da inabilità d'uso,
 - difetti derivanti da vizi, da eccesso o mancanza, da distribuzione di corrente elettrica o d'acqua o da cattivo funzionamento di apparecchiature ausiliarie o sussidiarie fornite da terzi,
 - difetti provocati durante il trasporto, lo scarico e l'installazione.
 - 10.3) Eventuali malfunzionamenti e anomalie dovranno essere comunicati entro otto giorni dalla data della loro rilevazione. Sarà premura della venditrice inviare in porto franco-destino i materiali in sostituzione fermo restando l'obbligo da parte del compratore di restituire, sempre franco porto al destino, i materiali difettosi. Nel caso in cui si renda necessario l'intervento diretto della venditrice saranno a carico del compratore le spese di viaggio, trasferimento, e manodopera.
 - 10.4) I reclami concernenti la garanzia non modificano in alcun modo i termini di pagamento. Pertanto il compratore non può assolutamente sospendere o ritardare i pagamenti.
 - 10.5) La richiesta di intervento presentata alla venditrice sarà presa in considerazione solamente se sarà accompagnata dal numero di matricola del prodotto venduto e dalla data della fattura di acquisto e da ogni altra informazione necessaria per la corretta identificazione del prodotto.
 - 10.6) La garanzia cessa automaticamente se il compratore si pone nelle condizioni del paragrafo 5.2.
 - 10.7) In nessun caso la venditrice potrà essere ritenuta responsabile dei danni ai prodotti del compratore, derivanti direttamente o indirettamente dai difetti della merce venduta.
- 11) Salvo quanto stabilito ai punti 7 e 10 nessuna altra responsabilità potrà essere addossata alla venditrice. Si conviene espressamente che il compratore non potrà avanzare pretese per danni a persone o cose o per danni dovuti a lucro cessante.
- 12) Con il presente ordine il committente rinuncia a tutte le eventuali diverse condizioni contenute nelle lettere, note o formulate verbalmente o per iscritto da agenti o collaboratori della venditrice. Qualsiasi modifica delle presenti condizioni o aggiunta di altre dovrà essere fatta per iscritto.
- 13) Tribunale competente per qualsiasi controversia è il foro di Mantova salva la facoltà della venditrice di adire il foro del compratore.
- 14) Si dichiara di aver presa attenta visione delle clausole a stampa contenute nella presente Commissione, di accettarle e di approvare specificatamente anche le clausole 1,2,4,5,6,8,9,10,11,12,13. Si approva inoltre in ogni parte il patto di riservato dominio di cui al punto 5.1.

Il presente listino sostituisce tutti i precedenti.

The goods specified are sold in accordance to the general conditions of sale indicated in the order form, in the confirmation of the order and hereafter indicated.

- 1) Unless otherwise agreed upon by the parties, all the deliveries shall occur ex factory. This risk transfer excludes the suspension or the delay of payment, motivated with damage occurred during the transport. If the seller considers necessary a special packing, this will be invoiced at cost price.
 - 1.1) The goods travel at buyer's risk, even if delivered free port.
- 2) The order is binding for the seller only after its confirmation in writing, whereas for the buyer it is binding after ordering.
- 3) Prices, measurements, weight and technical data specified in the price lists, catalogues, circulars or other advertising material (except if contractually defined) must be considered only indicative, due to market price fluctuation and due to modifications made for technical and aesthetic adaptation needs.
- 4) The specified delivery terms are only indicative and in any case the buyer can neither claim any reimbursement for damages due to late delivery nor can a delivery delay be the cause for the avoidance of the contract.
- 5) PAYMENT
 - 5.1) The goods are sold with retention of title and remain supplier's property until the buyer has paid for them in full. The property of the goods supplied shall pass to the buyer only when the last instalment will be paid. Any utilisation or handling of the goods before paying them in full shall be authorised by the seller.
 - 5.2) In case that also only one instalment won't be paid, the seller shall claim the immediate payment of the whole residual price, including the due instalments (art. 1186 C.C.). Furthermore the seller will have the right to avoid the contract and suspend the supply, in case that the agreement will be still in phase of execution. The seller will be entitled to claim any damage occurred.
 - 5.3) The place of payment is the seller's seat.
- 6) Any circumstance occurred independently of the seller's willingness and preventing him from the regular execution of the order is considered a right reason to exempt him from its execution. Are considered "independent of the seller's willingness" all the circumstances that are not caused by the seller's heavy guilt. In such a case the seller must inform the buyer in writing at the beginning and at the end of the existence of the reason. In case that it would be impossible to execute the order with a reasonable delay, every party will have the right to avoid the contract with a simple communication in writing.
- 7) The buyer must verify the conformity of the material on receipt of goods and, in case of complaint, he must inform the seller immediately. Any claim must be brought to the attention of the seller within 14 days from the date of shipping. Beyond this term any claim will not be accepted. Any defect found after the risk transfer can't be complained.
- 8) If the buyer, due to any cause which doesn't depend on the seller, doesn't collect the goods within the contractual terms, he will have to pay the complete price of the supply, including the part eventually still to be delivered. The buyer will be charged with the storage, risk and financial costs as well as with any other cost occurred in order to keep the goods ready for shipping. Furthermore there will be valid eventual price rises occurred in the meantime. Further damages that the seller has suffered are not included.
- 9) In case of avoidance of the contract due to buyer's willingness, he must immediately pay 30% of the price agreed upon, in accordance with art. 1382 (C.C.), without any prejudice about the right to claim damages eventually occurred to the seller.
- 10) WARRANTIES
 - 10.1) Considering the particularity of the goods sold, the seller warrants them for the normal conditions of use, as specified in the catalogue, during the period of 24 months from date of delivery. During this period the seller grants, at its only discretion, to replace or to repair the parts that would be acknowledged as faulty.
 - 10.2) The warranty doesn't include:
 - electric parts and checking automatism's,
 - defects due to major force,
 - any component of goods, if violation or modification was made by personnel which was not authorised by the seller,
 - defects arising from imperfection installation,
 - defects arising from an insufficient maintenance or cleaning,
 - defects arising from inability during use,
 - defects arising from faults, excess or lack of distribution of electric power and water or arising from malfunction of auxiliary or subsidiary instruments supplied by third parties,
 - defects caused during transportation, unloading or installation.
 - 10.3) Eventual malfunctions and anomalies must be communicated within 8 days from the date of bearing. The seller shall send free of charge the materials to be substituted and the buyer shall return free of charge the faulty materials. In case that a seller's direct intervention will be necessary, the cost of travelling, transfer and labour will be charged to the buyer.
 - 10.4) The warranty claims don't modify the payment terms and therefore the buyer can't suspend or modify the payments.
 - 10.5) the intervention's request will be taken into consideration by the seller only if it will be accompanied by the part number of the product sold, by the date of the invoice and by any other information necessary to identify the product.
 - 10.6) The warranty stops automatically if the buyer will be in any of the conditions specified in section 5.2.
 - 10.7) The seller shall not be liable for any damage occurred to the buyer's products, arising directly or indirectly from defects of the goods sold.
- 11) Except what established in section 7 and 10, any other responsibility can burden the seller. It's expressly agreed upon that the buyer can't claim any damages to people or thing or loss of profit.
- 12) With this order the buyer renounces to all the different conditions eventually contained in the letters or notes done in writing or verbally by agents or collaborators of the seller. Any modification of the present conditions or additions of other shall be done in writing.
- 13) The Mantova (Italy) competent law court shall have jurisdiction for any claim arising out or in connection with this agreement, except the faculty the seller has to apply to the court of the buyer.
- 14) The parties declare that all the printed clauses included in this order form have been carefully examined, that they accept them and that they specifically approve also the sections 1, 2, 4, 5, 6, 8, 9, 10, 11, 12, 13. The parties furthermore declare to fully approve the retention of title as specified in the section 5.1.

This price list replaces all previous ones.

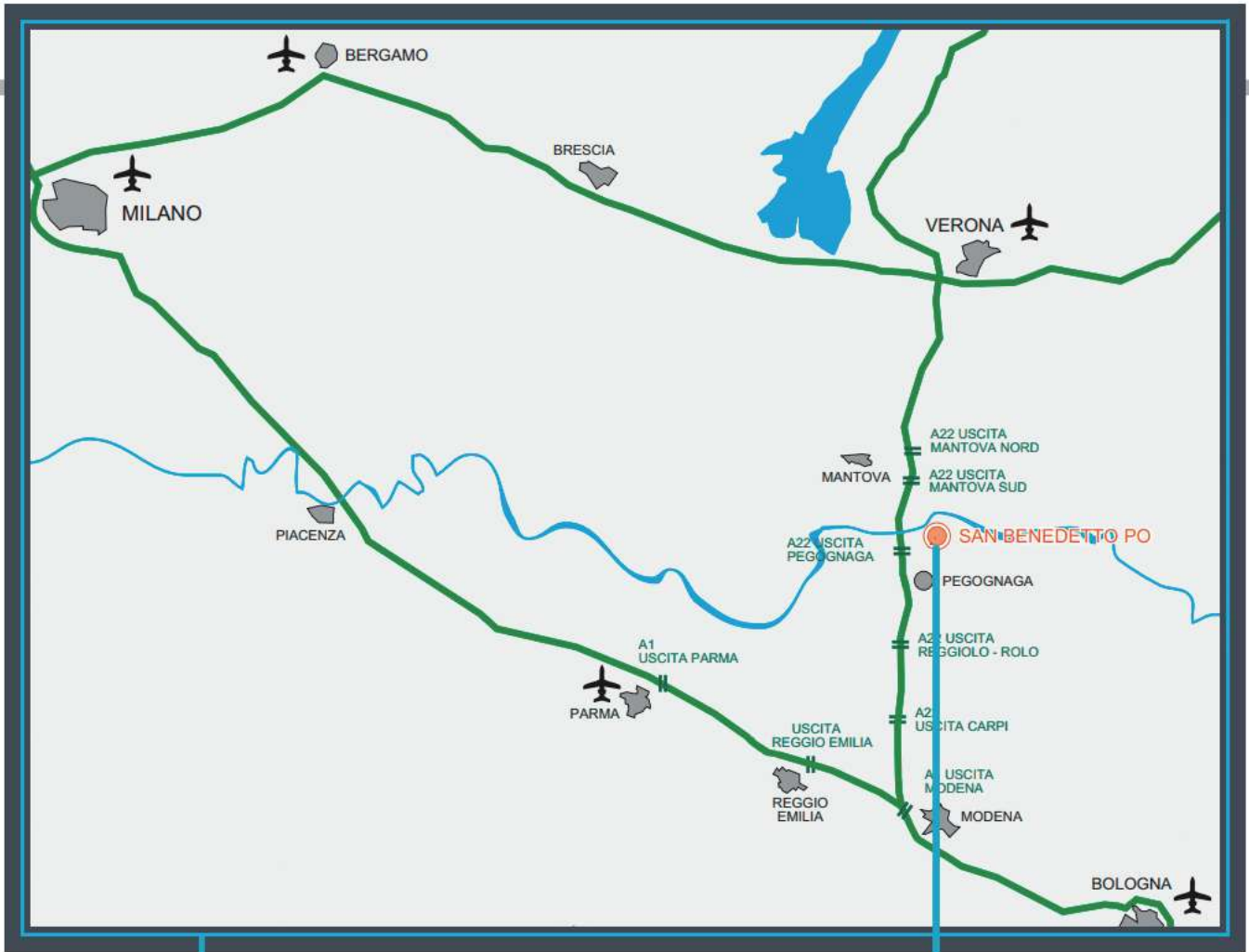

FOLLONI
AIR COMPRESSORS

Produced by LA PADANA Air Compressors

QUALITY MADE IN ITALY



Head Quarter: Via Maestri del Lavoro, 1 - 46027 SAN BENEDETTO PO (MN) - ITALIA
Tel. +39.0376.558282 - Tel. +39.0376.615166 - Fax +39.0376.558301

www.lapadana.it - E-mail: info@lapadana.it